

LED-BEACONS

LUXOR mini

The small, robust LUXOR mini is a powerful LED beacon for every application.

Product features:

- **Different types of assembly**
 - **Fixed-Mount**
 - **Pole-Mount**
 - **Magnetic (approved up to 250 km/h)**
- **Various adjustable flash modes**
- **Very good warning effect**
- **Impact-resistant polycarbonate-coloured domes**
- **Suitable for 12/24 V.**
- **Day approval according to ECE R65 class 2**

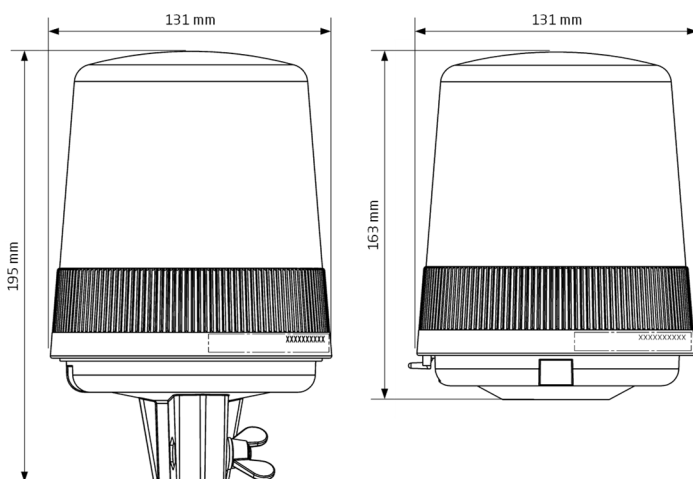

ARTICLE NUMBER	DESCRIPTION
002290401651	LUXOR-mini, blue, fixed mount, 35mm
002290301651	LUXOR-mini, blue, pole mount
002290411651	LUXOR-mini, blue, with adaptor
002290701651	LUXOR-mini, blue, magnetic, CLP
002290400651	LUXOR-mini, amber, fixed mount, 35mm
002290300651	LUXOR-mini, amber, pole mount
002290409651	LUXOR-mini, red, fixed mount, 35mm
002290309651	LUXOR-mini, red, pole mount

TECHNICAL DATA

operating voltage	12 / 24 VDC (10.8 ... 28.8 VDC)
current consumption	at 12V: 1.3 A; 3.5 A peak at 24V: 0.7 A; 1.7 A peak
flashing frequency	2.1 Hz (acc. ECE R65 class 2)
luminous intensity	280 cd (blue, day mode)
protection class	IP 56
mounting	magnetic-, pole-, fixed mounting
colours	blue, amber, red
ambient temperature	
- operation	-40 °C ... +70 °C
- storage / transport	-40 °C ... +80 °C
dimensions	diameter: 131 mm height: 160 ... 195 mm according to variant
weight	approx. 900 g (magnetic version without cable)
approvals	E1 TB2 - 003346 (blue) E1 TA1 - 003731 (amber) E1 10R - 046927 (EMC)