

Control Panel BT-CH / BT-CH2

The versatile options of the BT-CH and BT-CH2 cupholder control panels - the perfect solutions for individual control in your vehicle. Thanks to an extensive selection of backlit button caps, you can not only choose your own personal design, but also adapt the functions to your specific application.

The cupholder controls are particularly suitable for concealed installation or situations where installation space is limited. Their unobtrusive integration allows them to blend seamlessly into your vehicle without detracting from its aesthetic appearance.

The customizability of the functions allows you to configure the buttons according to your individual requirements. Whether used as a stand-alone system or in conjunction with the MS-350 to control the lightbar, the cupholder controls offer a flexible solution for different operating requirements.

The backlit keycaps not only improve the aesthetics, but also the operability in poor lighting conditions.

Experience a new dimension in vehicle operation with the BT-CH and BT-CH2 cupholder control panels - for individual, unobtrusive control in line with your needs.

Product features:

- **9 programmable backlit buttons for quick and safe operation, even at night**
- **Installation in the cup holder device**
- **Ideal for concealed installation**
- **Control via CAN bus**
- **12V capable**



Available keycaps
(will be extended if required)

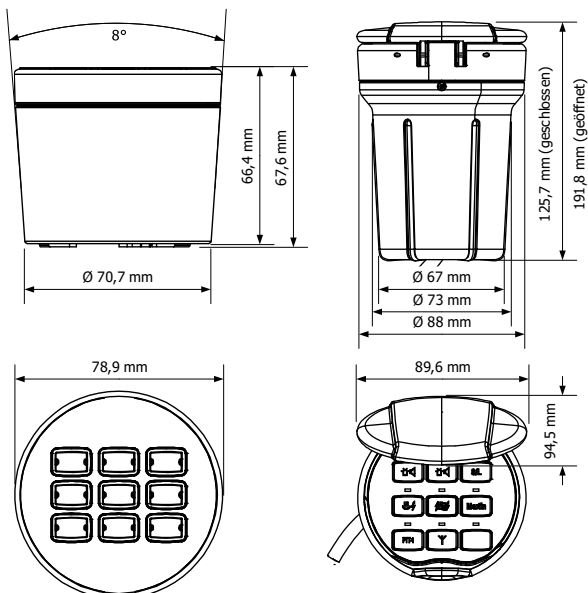

TECHNICAL DATA	
Nominal voltage	12 VDC (9 ... 14,4 VDC)
Current consumption	approx. 100 mA
Number of keycaps	9
Protocol	CAN-Bus, CiA447
Protection class	IP40
Ambient temperature	-40°C ... +80°C
Weight	
- BT-CH	230 g
- BT-CH 2	120 g
Approval	ECE R10