

MS6D 6LED+6LED DUAL COLOUR LIGHTHEAD

Adhesive Mount

1. Select a mounting location and clean the surface.
2. Peel one side of the adhesive and apply to the lighthouse base.
3. Peel the other side of the adhesive and secure the head firmly to the surface.

NOTE: Optimum adhesive strength is achieved after 24hrs.

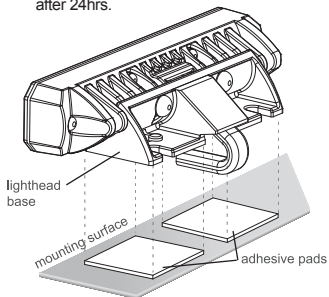

Screw Mount

1. Select a mounting location for the lighthouse.
2. Mark and drill mounting holes.
3. Place the rubber pad to the bottom of the base.
4. Secure the head to the mounting surface with supplied screws.

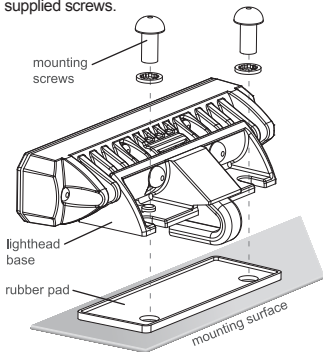

Bracket Mount

1. Select a mounting location for the lighthouse.
2. Place the rubber pad to the bottom of the base.
3. Place the head to the mounting surface.
4. Align top holes of the bracket onto the lighthouse base alignment points.
5. Secure the head with supplied screws from the bottom of the bracket.

