

WIRING 2 KITS TOGETHER

In this wiring illustration, different alternating flash patterns can be achieved.

If a "split" flash pattern* is selected:
Heads 1 & 4 will alternate with Heads 2 & 3.

If "all" flash pattern* is selected:
Heads 1 & 2 will alternate with Heads 3 & 4.

*refer to Flash Patterns chart on opposite page.

NOTE: To have Heads 1 & 3 alternate with 2 & 4, leave all WHITE wires disconnected and select a "split" flash pattern.

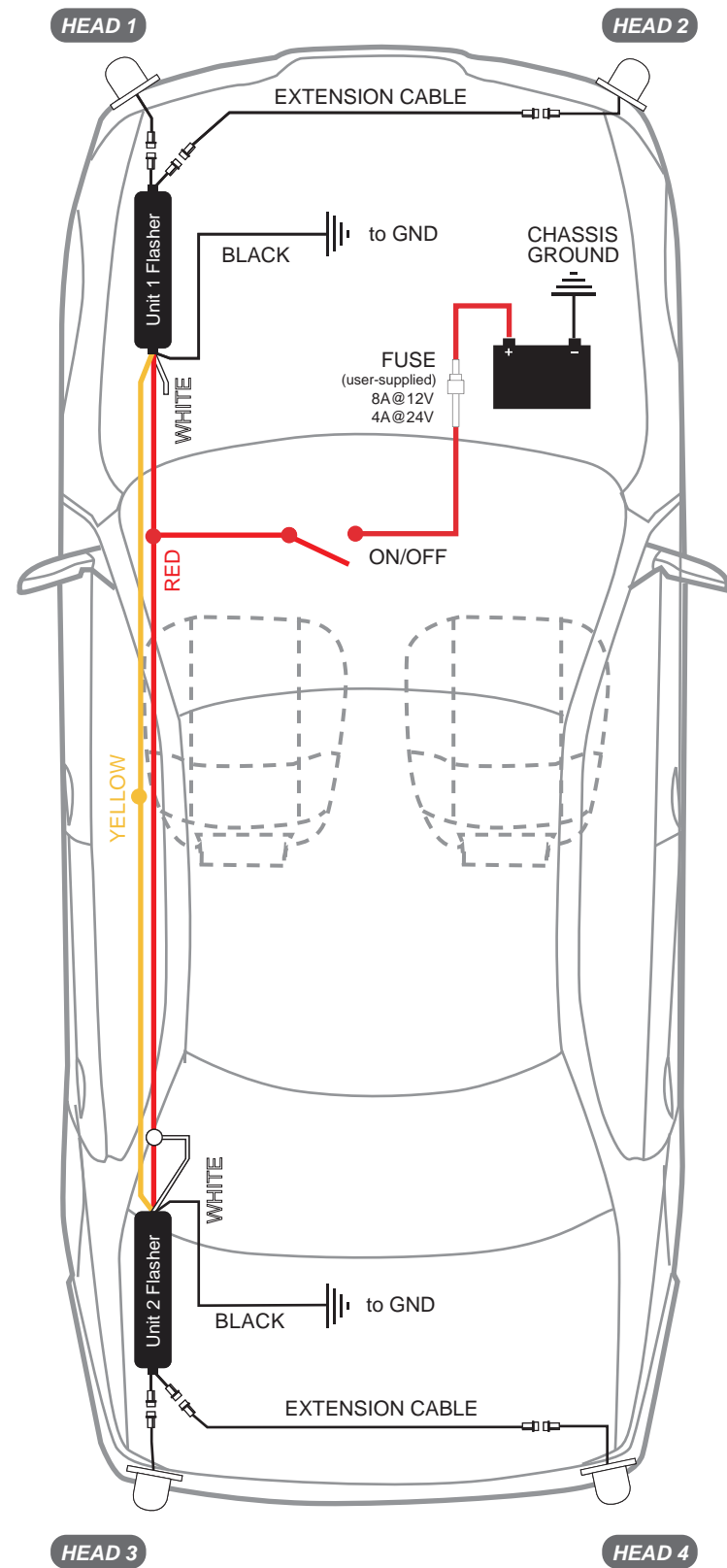

NOTE: Illustration only, not to scale.

HAL09W UNDERCOVER LED KIT USER MANUAL

KIT CONTENTS



SAFETY MESSAGE

The HAL09W lightheads are for use with HAL09W flasher only; do not use any part of this kit with other flashers or lightheads; it may cause damage and void warranty.



HAL09W



HAL09

LIGHT ASSEMBLY INSTALLATION

1. Remove the Corner/Head/Tail light from vehicle.
2. Select the location to mount the lighthead.
3. Carefully drill 1 inch diameter hole to the light assembly.
4. Insert lighthead into hole and secure with supplied sheet metal screws.
5. Apply silicone (user-supplied) for better seal.

WARNING: DO NOT cover heat sink with silicone. It may cause damage to the product and void warranty.

NOTE: Carefully select the location to mount the lighthead to achieve optimum effect as vehicle reflectors may vary.

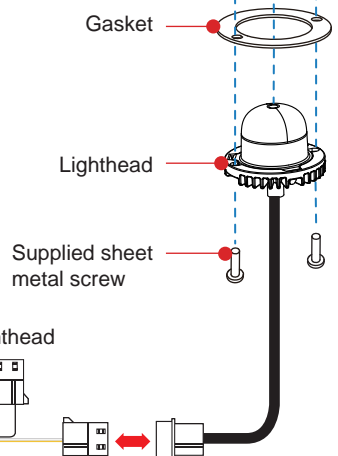
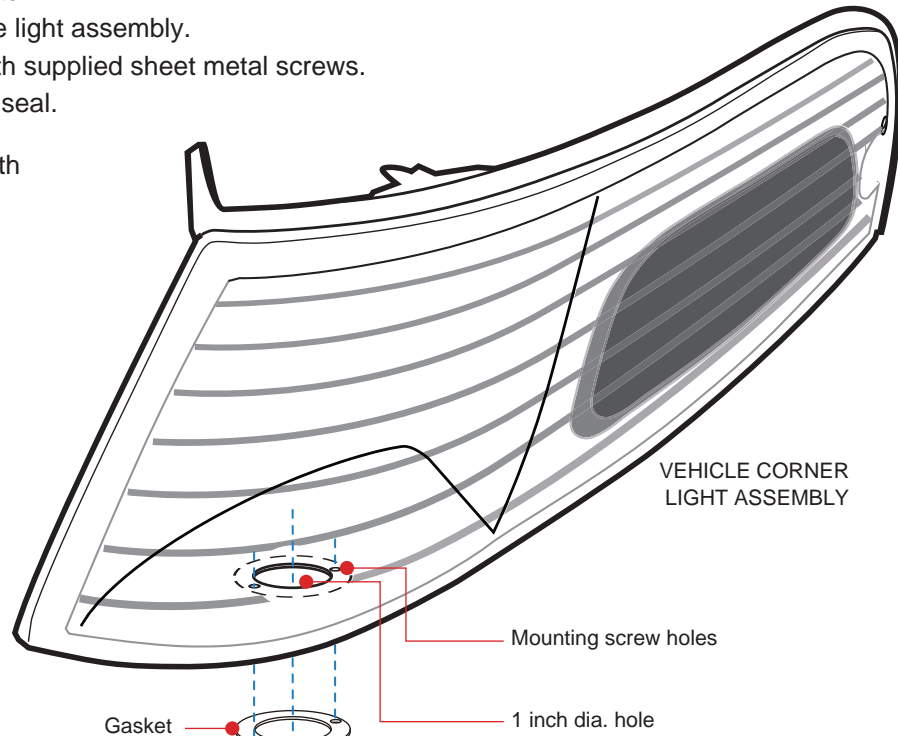

FP#	Flash Patterns
1	Random
2	Single (split)
3	Double (split)
4	Quad (split)
5	Quint (split)
6	Mega (split)
7	Ultra (split)
8	Single-Quad (split)
9	Single H/L (split)
10	Single (all)
11	Double (all)
12	Quad (all)
13	Quint (all)
14	Mega (all)
15	Ultra (all)
16	Single-Quad (all)
17	Single H/L (all)
18	Steady Half
19	Steady All

*SPLIT = Head 1 alternate Head 2
 *ALL = Head 1 & 2 Simultaneous

NOTE: This unit may not be factory set at FP# 1.

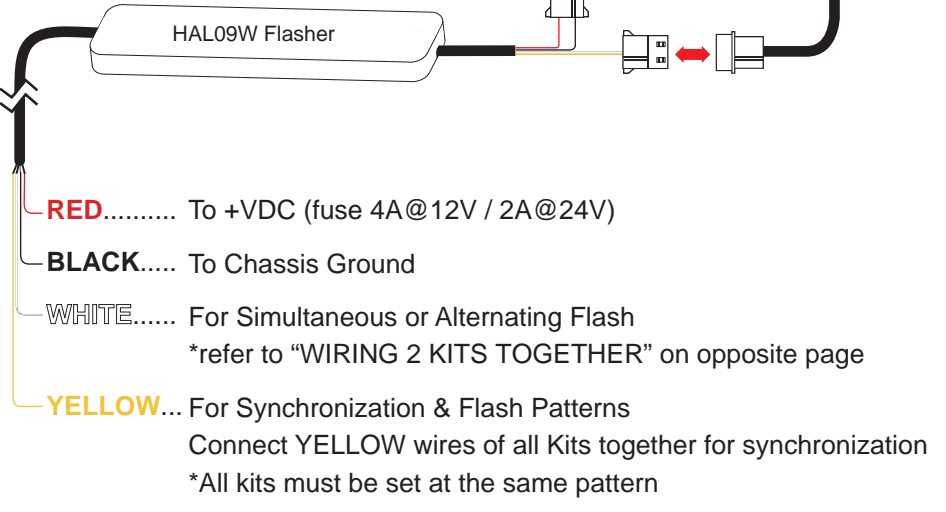

Momentarily apply +VDC to **YELLOW** wire:

- once for next pattern
- quickly three times for FP#1

WARNING: Make sure the LED lightheads do not interfere with the operation of vehicle lights.

FLANGE MOUNT INSTALLATION

1. Use the mounting foam to mark wire and screws holes before drilling.
2. Carefully drill marked holes accordingly.
3. Insert the lighthead pigtail into wire hole.
4. Place the foam, the lighthead, and the flange in line with the mounting holes, and secure with supplied sheet metal screws.

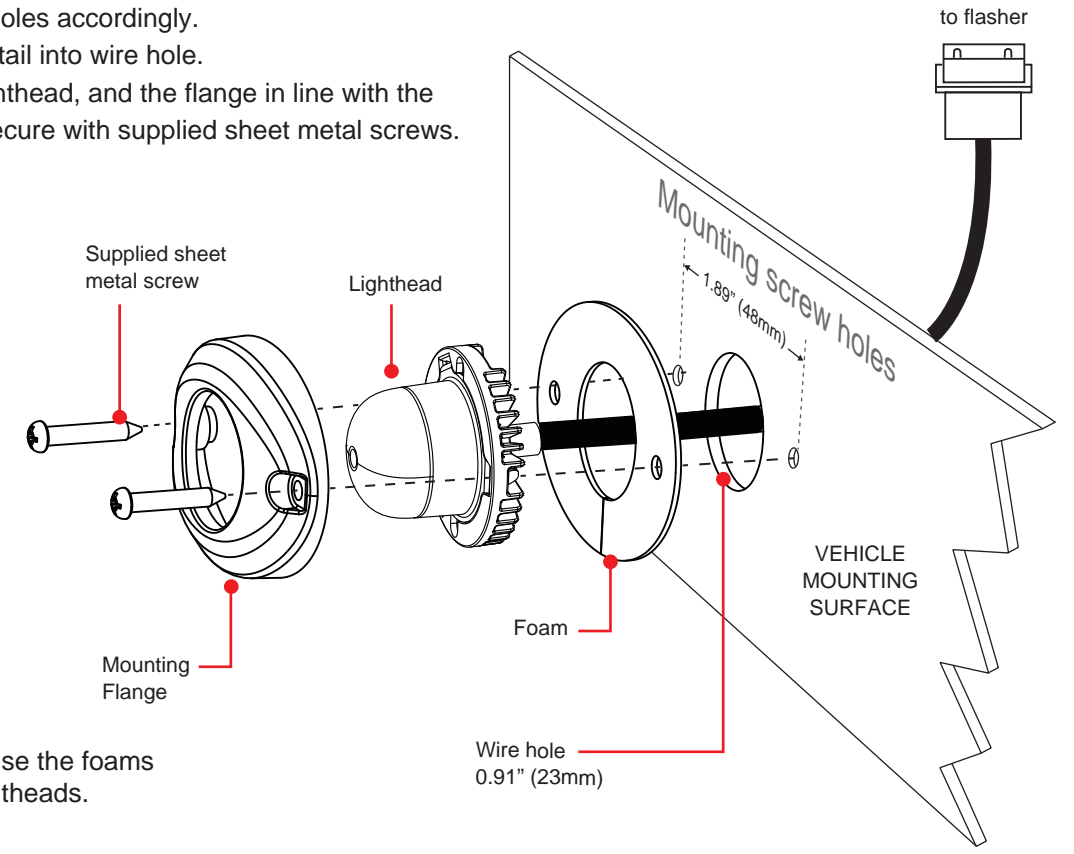

NOTE: Make sure to use the foams when mounting the lightheads.

WIRING TO EXISTING STROBE CABLES

If the vehicle already has a strobe kit installed, the existing extension cables can be utilized to facilitate installation.

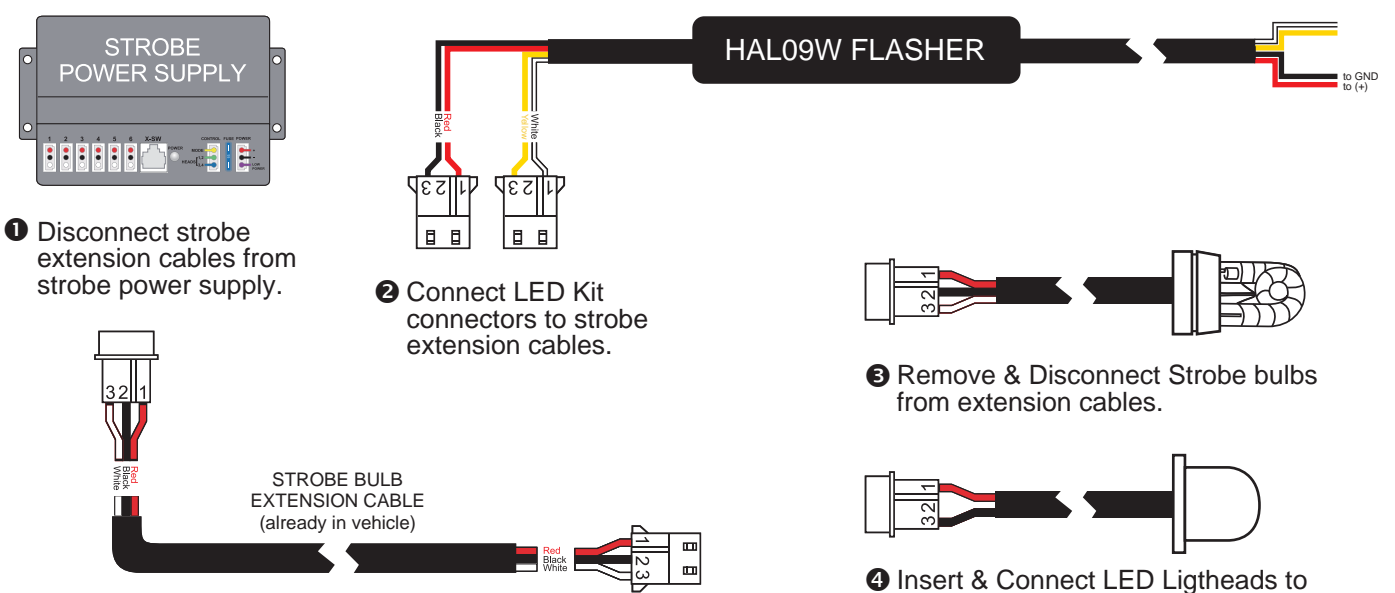

1. Disconnect strobe extension cables from strobe power supply.
2. Connect LED Kit connectors to strobe extension cables.
3. Remove & Disconnect Strobe bulbs from extension cables.
4. Insert & Connect LED Lightheads to strobe extension cables.

NOTE: Wire colors of the LED Kit do not need to match the wire colors of the extension cables.

WARNING: Do not connect LED lightheads directly to strobe power supply. It will cause damage and void the warranty.