

Hazard Warning Control Systems

for **Emergency Services** and **Commercial & Recovery Vehicles**



STANDBY[®]



Market Leaders in **Specialised Automotive Products & Telematics**

Introduction

Welcome to our new Control Systems catalogue, and in doing so you may also note a rebranding of our corporate identity reflecting the new ownership of RSG Engineering. In September 2020, RSG Engineering was acquired by Standby AB, based in Trolhätton Sweden, it is the largest supplier and manufacturer of emergency warning equipment in Europe with subsidiaries in France, Germany and Finland and a Group turnover of over £40m.

Founded in 1978, Standby share the same customer focused values that we have always held at RSG Engineering and now that we are part of a much larger organisation this will enable us to deliver a much wider range of products and services for the benefit of all our customers.

This, our Control Options catalogue, is dedicated to the control of vehicle hazard lighting and audio systems along with associated auxiliary items. We also have a variety of additional publications covering Hazard Lighting, Utility Lighting, Telematics and Video each offering an extensive range of hazard warning equipment for the emergency services and recovery services markets.

Installation and Training

Installation training for RSG products and systems can be carried out in our workshop or at your premises dependent upon the product specification. All of our engineers are fully trained and qualified with expertise in their own specialist field.

We have also created a range of training programs for our range of telematics, vehicle video and journey data recorders in order that customers can make the most of the data provided from these devices.

Experience

All of our product and system engineers have expert knowledge of the complexities of modern vehicle design as well as their electronic and electrical control systems such as CAN Bus.

Craftsmanship

In addition to their engineering abilities our installation team take great pride in their workmanship. They endeavour to demonstrate that all new wiring is installed as an integral part of the vehicle's original wiring loom, and, that all panelling is replaced correctly and in it's original condition. In fact, there will be little or no effect on body work, trim, panels or CAN bus data.

Full Service

Whether you have a single vehicle or a fleet, RSG has a range of products that offers a complete package including hazard warning lighting, telematics & data recording devices and control systems. In conjunction with this, RSG can provide an expert installation advisory service.



Manufacture

Having our own in-house manufacturing facility enables us to provide that extra level of service. Being able to modify and manufacture equipment on site is of great benefit especially when dealing with special requirements.

We manufacture and assemble a range of products including lightbars, warning lighting and switch panels either to customer specification or to ensure stock levels are kept to a maximum.

Development

New product development and bespoke engineering projects are carried out by our experienced in-house product design team who utilise the latest CAD software.

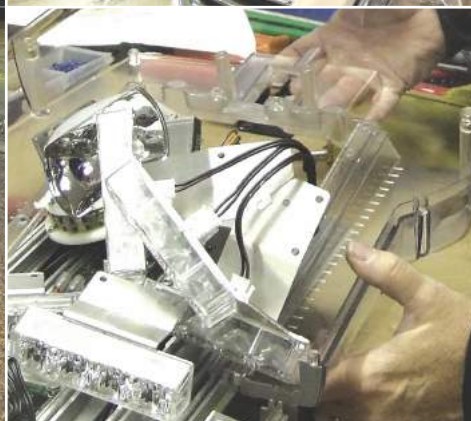



Market Leaders in Specialised Automotive Products & Telematics

Contents

Section 1 :

MCS Compact Control Systems

- 1:2 Uno System
- Uno Advanced System
- 1:3 Uno Latching System
- Uno Momentary System
- 1:4 Mini System (6 outputs)
- 1:5 Midi System (12 outputs)
- 1:6 Maxi System (12 outputs)

Section 2 :

MCS Control Units

- 2:10 MCS-32 Control Unit
- 2:12 MCS-32S Slave Unit
- 2:14 MCS-16 Control Unit
- 2:16 MCS-8 Control Unit
- 2:18 MCS-H16 Control Unit

Section 3 :

MCS Expansion Units

- 3:21 MCS-5E Universal Load Switch
- 3:22 MCS-LBC10 Lighting Breakout Controller
- 3:23 MCS-LBC20 Lighting Breakout Controller
- 3:24 MCS-CANIO CAN Bus Interface Module
- 3:25 MCS-CIM CAN Interface Module
- 3:26 MCS CAN Bridge Devices

Section 4 : MCS Sirens & Speakers

- 4:30 MCS-DDSA 200W Digital Siren
- 4:32 MCS-DSA 60W Digital Siren
- 4:33 MCS-SE 100W Siren
- 4:34 MCS-SSA Basic 100w Siren
- 4:35 Siren Speaker Range
- 4:37 Speaker Selection Chart
- 4:38 MCS-AIC Audio Intercom Controller

Section 5 : MCS Switch Units & Panels

- 5:42 MCS Switch Units and Panels Guide
- 5:44 T8 Mini Switch Unit
- T10 Midi Switch Unit
- 5:45 T16 MaxiPlus Switch Unit
- 5:46 T17 Universal Handset
- T17 Display Handset
- 5:47 F5, F5D & F5T Slimline Switch Unit
- 5:48 F14 Maxi Switch Unit
- F16 MaxiPlus Switch Unit
- 5:49 F21 Mega20 Custom Switch Unit
- Hand Held Microphone
- Handset and Microphone Adaptor
- Handset Hub
- Panel Mount Microphone
- 5:50 T8A Mini Switch Panel
- T16A MaxiPlus Switch Panel
- 5:51 P12 MidiPlus Switch Panel
- P16 MaxiPlus Switch Panel
- 5:52 MCS-TSC Touch Screen Controller

Section 6 : Complimentary Devices

- 6:54 Standard Auto Recall
- High Power Auto Recall
- Revolution PA Lightbar
- Tornado PA Lightbar
- 6:55 Siren Speaker Selection and dB Rating Chart
- Budget PA System
- 6:56 Run Lock Solutions
- 6:57 Headlight Flasher Units
- Mini Dimmer Unit
- Indicator Inhibitor Kit
- 6:58 Battery Guard 2000
- PowerTector Battery Guards
- 6:60 Pure Sine Wave Inverters
- 6:61 Switches and Sundries

Section 7 : Supporting Technical Information

- 7:62 MCS Device Comparison Charts
- 7:64 Typical System Specifications
- 7:66 MCS Devices Connectors, Adaptors and Cables
- 7:70 Typical Vehicle Application Chart

Section 8 : Feature Products

- 8:72 Traffic Commander Matrix Display
- 8:73 Trail Blazer 2 Portable Mini Lightbar with Siren
- 8:74 Hurricane LED Lightbar
- 8:75 Silverblade LED Lightbar
- 8:76 SDA100W 100W Digital Siren and Speaker
- 8:77 SL157 Series LED Scene Light
- Magnetic Handset Holder
- 8:78 Vehicle Tracking and Video Systems

Section 1 :

MCS Compact Control Systems

MCS Compact Control Systems consist of one or two MCS-6E mini multi-functional control units complete with the appropriate switching option. They are quick and easy to set-up and ideal for installations that do not require a great deal of sophistication.

These systems offer a quick, simple and cost effective method of controlling hazard warning equipment on emergency services, commercial and recovery vehicles. They are ideal for vehicles that only require a small amount of hazard warning equipment such as recovery trucks, General Purpose (GP) Police Cars, Covert Police Cars and Private Cars used by Officers when on duty. They operate by simply translating the press of a button that in turn activates the associated individual or selection of outputs.

Switching Options

The strength of the Mini, Midi and Maxi systems are their ability to be programmed directly via a combination of key pad presses, that not only allows initial set-up to be rapidly achieved, but also quick implementation of any changes that may be required during the commissioning and sign-off process.

The double width combo buttons on the Mini, Midi and Maxi switch systems not only act as 'Hot Keys' by activating a number of small key functions at the same time, but also has a 'Double' or 'Triple' press action to control a mixture of functions required in special situations such as '999', 'ARRIVE' and 'RESET'.

The simplest operation is offered by the MCS-6E working in conjunction with one of the discreet switch options; UNO or UNO Advanced single cyclic button or the Multi-switch Latching or Momentary switch systems.

To maximise potential Universal Compact Controller systems ideally need to be installed alongside Standby RSG's complementary lighting, expansion units and sirens or alternatively may be used with client's legacy devices should they decide to do this.

MCS-6E Mini Control Unit

- 3 modes of operation depending upon firmware set-up
 - via multi-way handset data input - program directly from the handset, no separate PC required
 - via single cyclic 3-way momentary push button
 - via up to 6 discreet latching or momentary switch inputs where 4 are positive voltage levels and 2 are negative voltage levels to accommodate both positive and negative inputs
- 6 x 10 Amp solid state outputs
- Collective total current rating is 24 Amp
- Each output can be current protected set at either 5 or 10 Amps - no external fuses required
- Side light input for illumination control - positive Input
- Ignition input for wake-up control - positive Input
- Positive switched inhibit input for single, fixed channel - ideal for head light inhibit - will act as normal if not used
- Negative switched enable for single, fixed channel - ideal for controlling Rear Reds via hand brake 'ON' warning light/switch
- Lock Out function to inhibit the keypad when not in use. Ideal when the handset is stored in glove box
- Low battery 'auto shut down' feature sets in when voltage level falls below 11.5 volts for more than 30 seconds
- Automatic 'sleep mode' sets in after periods of inactivity or low voltage to reduce power draw from when vehicle engine is not running. Wakes up when battery voltage is at acceptable level, engine resumes running or a switch is pressed/ignition on
- Some systems can perform Headlight Flash functions - see individual specifications for details
- Mini, Midi and Maxi systems can give a momentary output for external devices
- 12 and 24 volt operation

Typical Applications:

BLUE

General Purpose (GP)
Police Cars
Covert Police Cars
Private Officers Cars

AMBER

Recovery Vehicles
Wide Load Transporters
Event Vehicles



Uno & Uno Advanced Systems

UNI-SIX-004 & UNI-SIX-006

A single cyclic 3-way momentary push button system with an MCS-6E.

Two versions are available. The UNO has two outputs per button press while the Uno Advanced has three outputs on the 1st press, two outputs on the 2nd press and an additional handbrake input to inhibit the 2nd press if the handbrake is not applied.

See page 1:2 for system specifications.



Multi Switch Systems

UNI-SIX-003 & UNI-SIX-005

Up to six discreet latching or momentary switches with an MCS-6E.

The latching unit has one switched input always associated with the same output, with 4 x positive and 2 x negative LATCHING inputs available. While the momentary unit has 4 outputs associated with one input, 3 outputs associated with the second input and 1 output associated with each of the remaining 4 inputs and where 'all' inputs require a momentary switch action.

See page 1:3 for system specifications.



Mini System

UNI-STD-001

A seven button remote handset with an MCS-6E.

The seven button handset provides six individual function buttons and one combination button. The combination button can have a multi-function 'HOT' key action depending on the required function.

See page 1:4 for system specifications.



Midi System

UNI-STN-001

A nine button remote handset with 2 x MCS-6E control units.

The nine button handset provides eight individual function buttons and one combination button. The combination button can have a multi-function 'HOT' key action depending on the required function.

See page 1:5 for system specifications.



Maxi Systems

UNI-STF-001

A fourteen button remote handset with 2 x MCS-6E control units.

The fourteen button handset provides twelve individual function buttons and two combination buttons. The combination buttons can have multi-function 'HOT' key actions depending on the required function.

See page 1:6 for system specifications.



Uno System UNI-SIX-004

A single switch solution that has a momentary cyclic option and also has dual colour (red/blue) LED illumination that changes colour with each press to display selected 'mode of operation' or to indicate an 'off' status.

Supplied with a pre-programmed MCS-6E Mini Control Unit.

Switch Details:

- Momentary 3-way cyclic switch with dual colour (blue and red) LED illumination that changes colour with each press to display the selected mode of operation or is unlit when off
- 22mm front bezel micro switch
- Brushed steel anti-vandal switch
- Dual colour LED - blue/red
- Ingress protected to IP65

Example Cyclic Solutions

BLUE LIGHT			AMBER LIGHT		
MODE 1	MODE 2	MODE 3	MODE 1	MODE 2	MODE 3
999	Arrive at Scene	Off	Towing	Roadside Working	Off

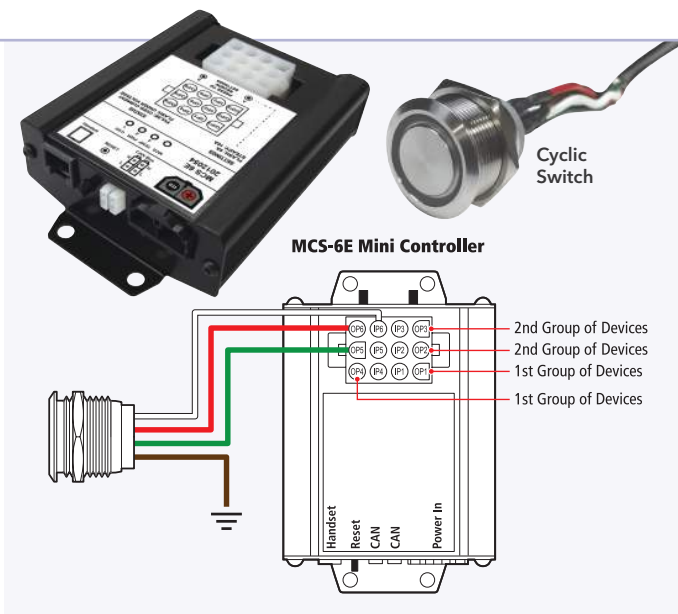

Input Relationship with Outputs		
INPUT	SWITCH	OPERATES
IP1	Not Used	No Action
IP2	Not Used	No Action
IP3	Not Used	No Action
IP4	Not Used	No Action
IP5	Not Used	No Action
IP6	1st Press 2nd Press 3rd Press	Off OP1 & OP4 OP2 & OP3

Output Functions			
OUTPUT	FUNCTION	EXAMPLE BLUE LIGHT USE	EXAMPLE AMBER LIGHT USE
OP1	1st Group of Devices	999 Group	Towing Group
OP2	2nd Group of Devices	At Scene Group	Roadside Working Group
OP3	2nd Group of Devices	At Scene Group	Roadside Working Group
OP4	1st Group of Devices	999 Group	Towing Group
OP5	Blue LED in Switch	Not Available To Use	Not Available To Use
OP6	Red LED in Switch	Not Available To Use	Not Available To Use

Note: Each output can drive any appropriate device so long as each is rated under 10 Amp with a collective total of 24 Amp.

Note: This device is specifically pre-programmed to operate as described above.

Uno Advanced System UNI-SIX-006

A single switch solution that has a momentary cyclic option and also has dual colour (red/blue) LED illumination that changes colour with each press to display selected 'mode of operation' or to indicate an 'off' status.

Supplied with a pre-programmed MCS-6E Mini Control Unit.

Switch Details:

- Momentary 3-way cyclic switch with dual colour (blue and red) LED illumination that changes colour with each press to display the selected mode of operation or is unlit when off
- 22mm front bezel micro switch
- Brushed steel anti-vandal switch
- Dual colour LED - blue/red
- Ingress protected to IP65

Example Cyclic Solutions

BLUE LIGHT			AMBER LIGHT		
MODE 1	MODE 2	MODE 3	MODE 1	MODE 2	MODE 3
999 and Extras	Arrive at Scene and Extras	Off	Towing and Extras	Roadside Working and Extras	Off

Note: Mode 1 is operational at all times.
Mode 2 is only operational when the handbrake is applied.

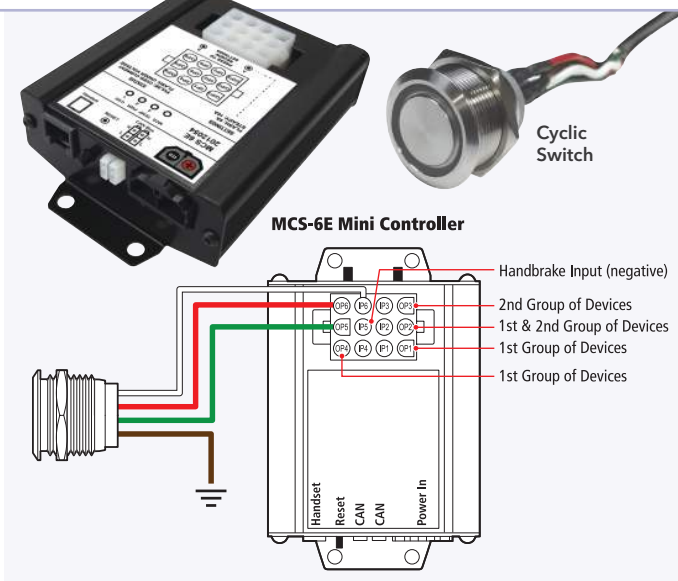

Input Relationship with Outputs		
INPUT	SWITCH	OPERATES
IP1	Not Used	No Action
IP2	Not Used	No Action
IP3	Not Used	No Action
IP4	Not Used	No Action
IP5	Handbrake	Internal Operation
IP6	1st Press 2nd Press 3rd Press	Off OP1, OP2 & OP4 OP2 & OP3

Output Functions			
OUTPUT	FUNCTION	EXAMPLE BLUE LIGHT USE	EXAMPLE AMBER LIGHT USE
OP1	1st Group of Devices	Front Blues	Front Ambers
OP2	1st & 2nd Group of Devices	Rear Blues	Rear Ambers
OP3	2nd Group of Devices	At Scene Group	Roadside Working Group
OP4	1st Group of Devices	999 Group	Towing Group
OP5	Blue LED in Switch	Not Available To Use	Not Available To Use
OP6	Red LED in Switch	Not Available To Use	Not Available To Use

Note: Each output can drive any appropriate device so long as each is rated under 10 Amp with a collective total of 24 Amp.

Note: This device is specifically pre-programmed to operate as described above.

Other options are available to order - contact our dedicated sales team for further information

Uno Latching System UNI-SIX-003

The MCS-6E Mini Control Unit is pre-programmed to accept up to 4 positive inputs and 2 negative inputs via suitable latched low current switches, however, not all have to be used as it depends upon the configuration required.

We have a selection of latching switches available to order, for further advice please contact our technical sales department.



MCS-6E Mini Controller

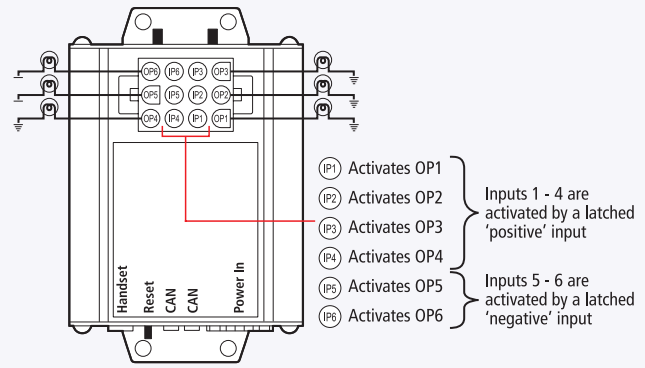

Input Relationship with Outputs		
INPUT	SWITCH	OPERATES
IP1	Positive	OP1
IP2	Positive	OP2
IP3	Positive	OP3
IP4	Positive	OP4
IP5	Negative	OP5
IP6	Negative	OP6

Output Functions			
OUTPUT	FUNCTION	EXAMPLE BLUE LIGHT USE	EXAMPLE AMBER LIGHT USE
OP1	1st Individual Device	Front Blues	Towing Lights On
OP2	2nd Individual Device	Rear Blues	Roadside Working Lights On
OP3	3rd Individual Device	Rear Reds	Rear Work lamps
OP4	4th Individual Device	Off-Side Alley	Front Work Lamps
OP5	5th Individual Device	Near-Side Alley	Winch Active
OP6	6th Individual Device	Siren Arm	Interior Lights On

Note: Each output can drive any appropriate device so long as each is rated under 10 Amp with a collective total of 24 Amp.
 Note: This device is specifically pre-programmed to operate as described above.

Uno Momentary System UNI-SIX-005

The MCS-6E Mini Control Unit is pre-programmed to accept up to 4 positive inputs and 2 negative inputs to instigate specific individual or multiple outputs (operations such as 999 Emergency Mode and At Scene) via suitable momentary low current switches, other formats may also be implemented.

We have a selection of latching switches available to order, for further advice please contact our technical sales department.



MCS-6E Mini Controller

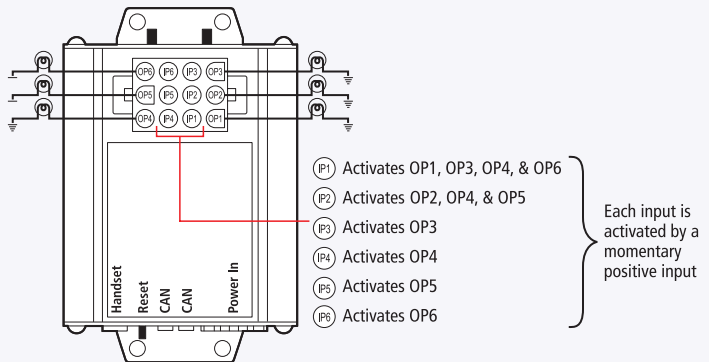

Input Relationship with Outputs		
INPUT	SWITCH	OPERATES
IP1	Positive	OP1, OP3, OP4 & OP6
IP2	Positive	OP2, OP4 & OP5
IP3	Positive	OP3
IP4	Positive	OP4
IP5	Negative	OP5
IP6	Negative	OP6

Output Functions			
OUTPUT	FUNCTION	EXAMPLE BLUE LIGHT USE	EXAMPLE AMBER LIGHT USE
OP1	1st Group of Devices	999 Group	Towing Group
OP2	2nd Group of Devices	At Scene Group	Roadside Working Group
OP3	3rd Individual device	Front Blues	Rear Work lamps
OP4	4th Individual device	Rear Blues	Front Work Lamps
OP5	5th Individual device	Rear Reds	Cruise Lights
OP6	6th Individual device	Headlight Flash	Interior Lights

Note: Each output can drive any appropriate device so long as each is rated under 10 Amp with a collective total of 24 Amp.
 Note: This device is specifically pre-programmed to operate as described above.

Other options are available to order - contact our dedicated sales team for further information

Mini System - 6 Control Outputs UNI-STD-001

One MCS-6E Control Unit and a 7 button handset provides 6 individual function buttons and 1 combination button. Based upon established tactile switch technology that can be 'user' programmed to suit a wide variety of applications.

They are quick and easy to set-up and ideal for installations that do not require a great deal of sophistication. With the ability to be programmed directly from the handset there is no need for a PC and associated software to configure the control unit.



HANDSETS FEATURES AND FUNCTIONS

- Each switch can be set with 1 of 8 back light colours upon each individual action and to suit switch function
- All Clear function. When activated, all buttons on the handset are turned off, and held off as long as the input stays active
- Buttons can be individually allocated with the use of standard self adhesive, pre-printed legends, or bespoke legends available to order
- 3 Stage back illumination - low when 'OFF', high when 'ON' both levels automatically dim when vehicle side lights are 'ON'
- Each small button can be latching or momentary
- Double width combo button can have a multi-function 'HOT' key double or triple action depending on required function and change colour depending on it's mode
- A fully tactile one piece wipe clean keypad with 'positive clicks'
- Option to enable 'beep' every time a button is pressed and/or 'beep' every 5 seconds when switch active
- Pressing a button or the ignition input wakes unit from 'sleep' mode so long as battery voltage is within operating range
- Supplied complete with protective rubber surround as standard which can be removed for dash mounted applications



Mini System - Typical Application Schematic UNI-STD-001

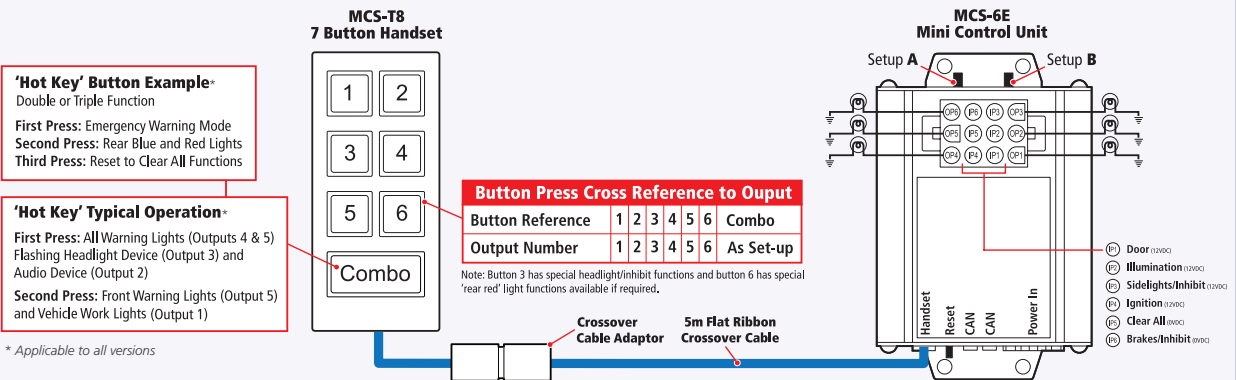

1:4

MINI SYSTEM COMPONENTS UNI-STD-001

DESCRIPTION	REPLACEMENT PART NO.
MCS-6E Mini Control Unit	UNI-SIX-001
MCS-T8 7-Way Handset (Blank)	UNI-MIN-026
Handset Clip	ACC-287
Flat Ribbon Crossover Cable	19-1412
Crossover Cable Extension Adaptor	19-1395
MCS-Mini Legend Sheet	17-1577

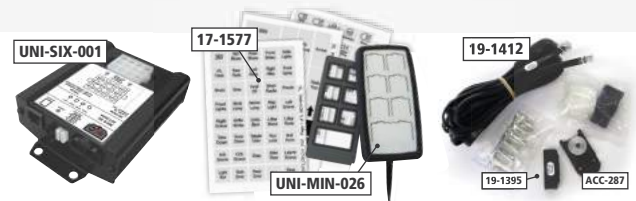

Midi System - 12 Control Outputs UNI-STN-001

Two MCS-6E Control Units are simply ganged together via a CAN Bus connection to double the systems control capacity. Providing two extra outputs with up to 8 individual or combined functions.

A 9 button handset provides 8 individual function buttons and 1 combination button. Based upon established tactile switch technology that can be 'user' programmed to suit a wide variety of applications.

The combination of two MCS-6E Control Units and a 9 Button Handset has all the features and functions of the MCS-MINI, but due to the increased number of switches and associated outputs it is ideally suited to applications needing more of both these operational facilities. Also, because there are actually more control lines (outputs) than switches this combination of devices is suited to applications where a single switch needs more than one output, for example flashing head lights, as one output is required per head lamp or alternatively alternating rear red lamps - note this feature is not available on the Mini or Maxi systems.

With the MIDI having 8 standard buttons, and 8 standard outputs there are some special operational features. For example output 9 is active when the first combination is active (say 999) and output 10 is active when the second combination is active (say At Scene). Therefore these would be useful for activating sirens when in the 'Response/999' combination mode, or perhaps activating 'Rear Reds' when in the 'At Scene' mode. That then leaves 2 outputs that are multifunctional. Where output 11 always follows button 3, where the user can configure the system so these buttons are steady on together (double the current draw) OR flash in an alternating pattern at 60BPM. With output 12 being capable of being configured to be active whenever any button is pressed OR is active whenever the unit is awake.



HANDSETS FEATURES AND FUNCTIONS

- Each switch can be set with 1 of 8 back light colours upon each individual action and to suit switch function
- All Clear function. When activated, all buttons on the handset are turned off, and held off as long as the input stays active
- Buttons can be individually allocated with the use of standard self adhesive, pre-printed legends, or bespoke legends available to order
- 3 Stage back illumination - low when 'OFF', high when 'ON' both levels automatically dim when vehicle side lights are 'ON'
- Each small button can be latching or momentary
- Double width combo button can have a multi-function 'HOT' key double or triple action depending on required function and change colour depending on it's mode
- A fully tactile one piece wipe clean keypad with 'positive clicks'
- Option to enable 'beep' every time a button is pressed and/or 'beep' every 5 seconds when switch active
- Pressing a button or the ignition input wakes unit from 'sleep' mode so long as battery voltage is within operating range
- Supplied complete with protective rubber surround as standard which can be removed for dash mounted applications

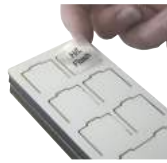

Allocate a button function, add the required legend



Seal with the one piece, wipe clean, screen protector

Midi System - Typical Application Schematic UNI-STN-001

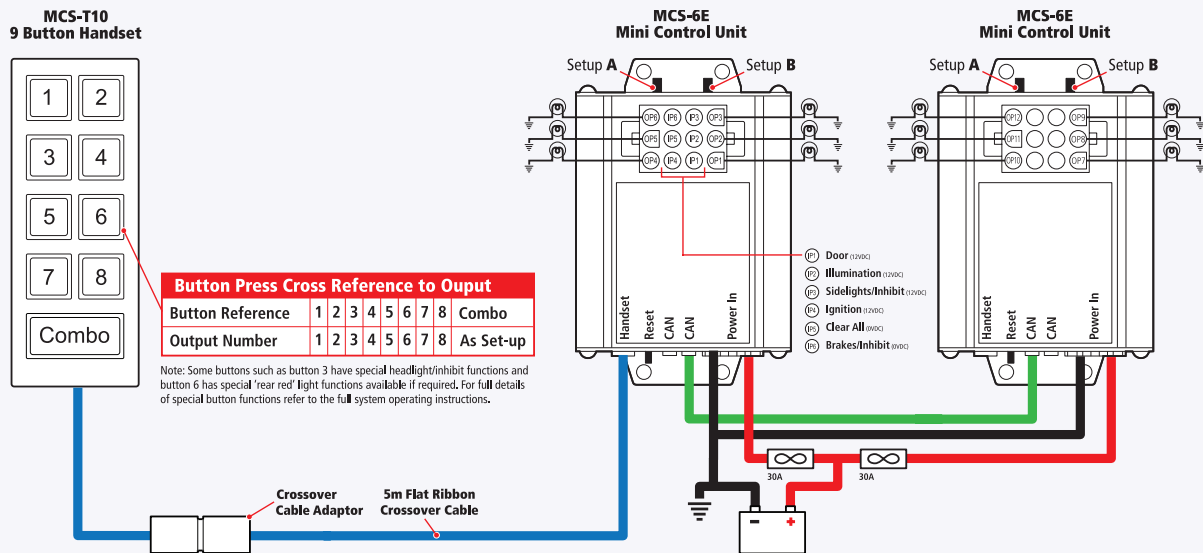

MIDI SYSTEM COMPONENTS UNI-STN-001

DESCRIPTION	REPLACEMENT PART NO.
MCS-6E Control Unit x 2	UNI-SIX-001
MCS-T10 9-Way Handset (Blank)	UNI-MID-013
Handset Clip	ACC-287
Flat Ribbon Crossover Cable	19-1412
Crossover Cable Extension Adaptor	19-1395
CAN Bus Connection Cable	22-1526
MCS-Midi Legend Sheet	17-1578



Maxi System - 12 Control Outputs UNI-STF-001

Two MCS-6E Control Units are simply ganged together via a CAN Bus connection to double the systems control capacity. Providing twice the outputs with up to 12 individual or combined functions.

A 14 button handset provides 12 individual function buttons and 2 combination buttons. Based on established tactile switch technology that can be 'user' programmed to suit a wide variety of applications.

Combining two MCS-6E Control Units and the 14 Button Handset has all the features and functions of the Mini System, but due to the increased number of switches and associated outputs it is ideally suited to applications needing more of both these operational facilities. Where having one switch function associated with a particular and specific output makes for a very easy set-up and application process, and for more complex installations a Combo switch can be matched with more than one output if required.

Having the option for 2 Combination Buttons also allows the user to have better control over applications that require a number of functions to be active at the same time and/or operate in a pre-defined manner.

Note: Because the handset has the same number of individual function buttons (12) as two MCS-6E Control Units (12) it does not have some of the 'special operational features' available with the Midi System such as headlight and rear lights independently flashing.



HANDSETS FEATURES AND FUNCTIONS

- Each switch can be set with 1 of 8 back light colours upon each individual action and to suit switch function
- All Clear function. When activated, all buttons on the handset are turned off, and held off as long as the input stays active
- Buttons can be individually allocated with the use of standard self adhesive, pre-printed legends, or bespoke legends available to order
- 3 Stage back illumination - low when 'OFF', high when 'ON' both levels automatically dim when vehicle side lights are 'ON'
- Each small button can be latching or momentary
- Double width combo button can have a multi-function 'HOT' key double or triple action depending on required function and change colour depending on it's mode
- A fully tactile one piece wipe clean keypad with 'positive clicks'
- Option to enable 'beep' every time a button is pressed and/or 'beep' every 5 seconds when switch active
- Pressing a button or the ignition input wakes unit from 'sleep' mode so long as battery voltage is within operating range
- Supplied complete with protective rubber surround as standard which can be removed for dash mounted applications



Allocate a button function, add the required legend



Seal with the one piece, wipe clean, screen protector

Maxi System - Typical Application Schematic UNI-STF-001

MCS-T16
14 Button Handset

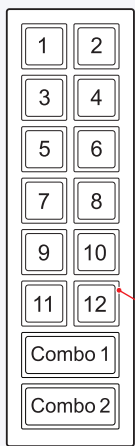

Button Press Cross Reference to Output														
Button Reference	1	2	3	4	5	6	7	8	9	10	11	12	Combo 1	Combo 2
Output Number	1	2	3	4	5	6	7	8	9	10	11	12	As Setup	As Setup

Note: Some buttons such as button 3 have special headlight/inhibit functions and button 6 has special 'rear red' light functions available if required. For full details of special button functions refer to the full system operating instructions.

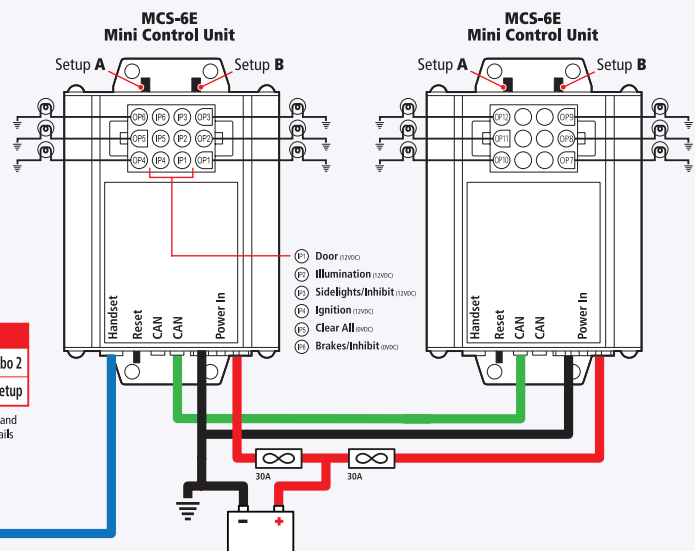

MAXI SYSTEM COMPONENTS UNI-STF-001

DESCRIPTION	REPLACEMENT PART NO.
MCS-6E Control Unit x 2	UNI-SIX-001
MCS-T16 14-Way Handset (Blank)	UNI-MXH-021
Handset Clip	ACC-287
Flat Ribbon Crossover Cable	19-1412
Crossover Cable Extension Adaptor	19-1395
CAN Bus Connection Cable	22-1526
MCS-Maxi Legend Sheet	17-1579



Cornwall Fire and Rescue

Grandland X

- MCS-8 Control Unit
- Momentary Cyclic Push Button
- Aegis LED Lightbar
- Mini Stealth LED Module
- Duo-1 LED Modules
- Micro Burst LED Modules
- LED Number Plate Warning Light
- Run Lock



Section 2 :

MCS Control Systems

MCS Control Units, Complementary Expansion Products and Multi-Way Switch Units

MCS Control Units are user programmable devices for managing hazard warning lights and power related functions on Emergency Services vehicles. Although standard units incorporate a 100 Watt siren with both UK and European tones, a selection are available that do not have this function. Incorporating a host of discrete on/off and various data protocol inputs and outputs these devices can control a wide variety of applications and if that's not enough they also come with a comprehensive set of specialised software modules specifically developed to meet the needs of current emergency services vehicles.

The main feature of these devices is their ability to be fully 'user' programmed. Any input or combinations of inputs can be used to control any output or combination of outputs as operationally specified for vehicles used by the Emergency or Recovery Services. Human machine interface is normally carries out via one of many Multi-Way Switch Units or individual switches. In addition to this, under certain conditions, the MCS range of control units will operate with some industry standard switches that are already in circulation or acquired from new. Also, if operationally required for larger systems the MCS range can control up to 4 Multi-Way and/or discrete individual switches.

The programming software is supplied free of charge with these devices and allows the user to create 'Configuration Files' unique to each application that can be easily amended or upgraded if required, thus, eliminating the need to add or remove relays and wires to an installation should the original specification change.

The primary function of the units is to control a vehicle lightbar in conjunction with other peripheral light heads, particularly when interaction with other vehicle functions such as opening the tail gate or handbrake operation are required. Where the human interface is via a wide variety of switching devices ranging from 5 button to 20 button hand-held or dash mounted options as well as simple arrays of discrete latching and/or momentary switches.

When a Multi-Way Switch unit is used, it is programmed using the MSC software allowing each switch function to be uniquely defined in terms of being either a single or a multi-functional switch (hot key) along with one of 8 colours.

The unit also has the ability to interface with vehicle CAN Bus signals or, alternatively, when fully developed operate with the Home Office

Single Vehicle Architecture CiA447 CAN Bus protocol as specified in publication 39/11. Therefore allowing vehicle operational signals to be obtained directly from its electronic control systems, such as the ECU, rather than picking up from the electrical/electronic signal associated with a particular vehicle function such as an indicator or brake light. Standby RSG has a comprehensive library of CAN Bus data that is available to users of MCS devices.

In addition to controlling blue lights and sirens the MCS's can also communicate with other devices usually found on an Emergency Services vehicle such as Data Recorders and MDT's this is usually achieved via it's CAN Bus or RS232/RS485 connections that in turn communicate with the vehicles Can Bus or CiA447 protocols if required.

For help with installation and fault finding MCS units are fitted with diagnostic LEDs, each of which can display one of three indication colours (green, amber and red) to give immediate feedback without the need for a PC connection.

If an MCS unit does not contain sufficient switching functions in its own right, additional expansion units such as the MCS-32S Slave Unit, MCS-5E Load Switch or MCS-LBC Lighting Breakout Controller can be added to expand the system. Alternatively, if the device is over specified for an application the smaller MCS-16, MCS-8 or MCS-SE 100 Watt Siren can be used along with the appropriate Multi-Way Switch unit. In addition to all that, some specialised modules like the MCS-AIC Audio Intercom Controller are also available. All of these and more complimentary devices are shown in more detail further on in this brochure.



Typical Applications:

- General Purpose & Fast Response Police Cars
- Covert Police Cars
- First Responder & Box Ambulance
- Roadside Recovery Tow Trucks
- Bus and Coach

MCS-32 Control Unit

A multi-functional control system for the operation of rooftop lighting, secondary lighting and power management.

The MCS-32 features 32 outputs and 24 configurable inputs and the option of a built-in siren. Power management functions include run lock, split charging, load shedding and headlight flash some of which can be implemented via the vehicle CAN Bus system.

See page 2:10 for product specifications.



MCS-32S Slave Unit

A device to expand the input and output functions of the MCS-32.

This slave unit is specifically designed to support the MCS-32 when additional outputs and inputs are required. This unit is also available with a built-in siren if required.

See page 2:12 for product specifications.



MCS-16 Control Unit

A multi-functional control system for the operation of rooftop lighting, secondary lighting and power management.

The MCS-16 features 16 outputs and 16 configurable inputs and the option of a built-in siren. Power management functions include run lock, split charging, load shedding and headlight flash some of which can be implemented via the vehicle CAN Bus system.

See page 2:14 for product specifications.



MCS-8 Control Unit

A multi-functional control system for the operation of rooftop lighting, secondary lighting and power management.

The MCS-8 features 8 outputs and 10 inputs and the option of a built-in siren. Power management functions include run lock, split charging, load shedding and headlight flash some of which can be implemented via the vehicle CAN Bus system.

See page 2:16 for product specifications.



MCS-H16 Control Unit

A multi-functional control and/or expansion module to operate as a master control units or multiple slaves.

The high powered MCS-H16 can be configured for use as a single stand alone master controller or ganged up with other H16 units set up as slaves. Alternatively it can be used as a heavy duty expansion unit alongside a MCS-32, MCS-16 or MCS-8 control unit.

See page 2:18 for product specifications.



MCS-32 Control Unit

For the operation of vehicle rooftop lighting, secondary lighting and power management

PRODUCT OVERVIEW

The MCS-32 Control Unit consists of a main control box which contains everything required to control a vehicle mounted hazard warning system, typically comprising rooftop lighting, secondary hazard warning lights and audio equipment. It has 32 outputs and 24 configurable inputs with power management functions including run lock, split charging, load shedding and headlight flash, plus many more, some of which may be implemented via the vehicle CAN Bus system. It also includes a logic switch module to facilitate the control of a Gateway radio with voice alerts.

Operate the controller through one of our range of fully compatible hand held or dash mounted switch units and you have an economical hazard warning control system that does not compromise on features or functionality.

System Intelligence

The main control unit is supplied with default settings that will suit a variety of applications, however it can be simply customised to match the end users specific application by plugging in to a laptop/desktop PC and utilising the 'easy to use' complimentary software.

Human Machine Interface (HMI)

We have developed a collection of switch units specifically designed to interface with the MCS-32. They range from a 5 button handset to a 20 button flush mount unit. Handsets have the facility to operate a Public Address (PA) system via an integral microphone and the option to allocate any button to operate the Push to Talk (PTT) feature.

One Source, One Solution

In order to simplify the installation process each unit is supplied fully loaded with all the necessary features and functions to implement a comprehensive system. Simply enable the required function via the 'easy to use' software.

Logic Functions

An abundance of logic functions means complex applications are no longer difficult to implement, particularly where certain operations are interlinked with others. So, carrying out 'and/or' functions and implementing 'do this when' or 'stop this when' are simple to apply together with the facility to alter functions allowing continual client synchronisation.

System Configuration

This is a simple 3-stage process which entails enabling and labelling inputs and outputs, configuring the system operation and downloading the application onto the unit. This operation need only be done once, when completed it can simply be transferred onto other units via a laptop.

MCS-32 COMPONENTS

PART NO.	DESCRIPTION
UNI-PLS-001	MCS-32 Control Unit with Siren, 12/24v
UNI-PLS-002	MCS-32 Control Unit without Siren, 12/24v
UNI-PRO-002	Universal MCS Software CD
ACC-256	MCS Programming Lead and CD

OPTIONAL BUILT-IN SIREN!

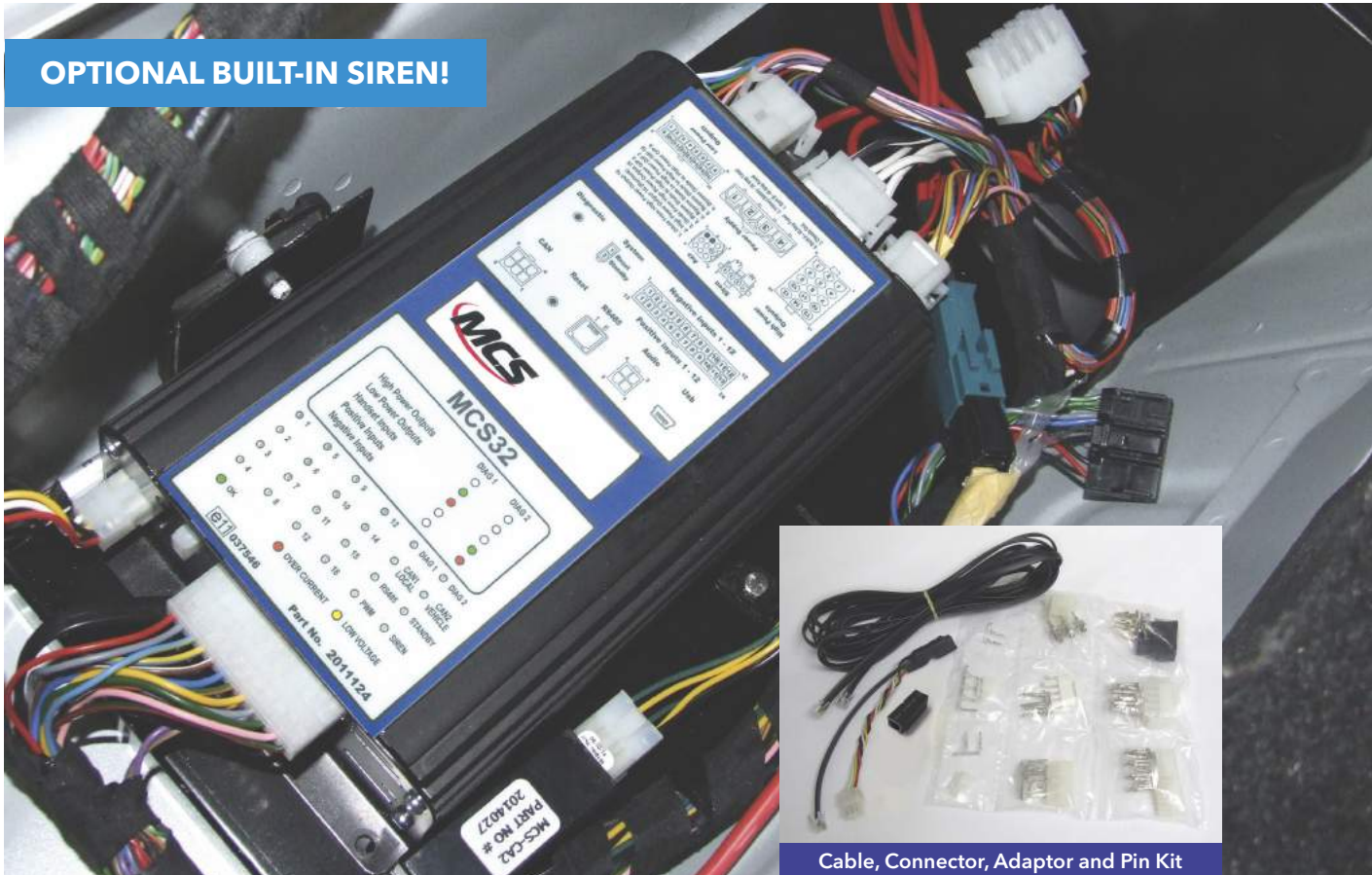

2:10

Section 2 : MCS Control Units

General Features and Functions

OUTPUTS

32 Outputs:

- 16 Hi Power Outputs
 - 20 Amps per channel
 - Current limiting
 - Multi flash patterns
 - Timer shutdown
 - Voltage drop out
- 12 Low Power Outputs
 - 600mA per channel
 - Positive or Negative switching
 - Provide monitoring signal inputs (not high impedance)
 - Negative polarity to switch low power relays
- 4 Medium Power Outputs
 - 2.5 Amps per channel
 - Positive & Negative polarity switching
 - Provide monitoring signal inputs
 - Drive relays
 - Small motors
- 2 diode pairs built in for headlight and/or tail light flashers
- Output to data logger
- Electronic Fuses
 - Electronically adjustable
 - Electronically tripped

INPUTS

- 24 Configurable Inputs
 - 12 negative switching
 - 12 positive switching
 - Software configurable
- 4 Standard Inputs
 - Mic input
 - Radio input
 - Reset
 - Standby

MULTI-WAY SWITCH OPTIONS

- Universal Multi-Way handset can be fully configured using the MCS software
- Single or up to 4 handsets

SERIAL DATA PORT

- RS485 protocol
- RS232 - via adaptor
- Link with third party MDT terminals
- USB Port

CAN OR CAN TYPE DATA PORT

- Link to Standby RSG complementary devices such as a lightbar
- Link to other industry new standard devices
- Link with legacy equipment

USER INTERFACE

- 24 illuminated status indicators
- Indicates flash pattern
- Communication status
- Provides output status
- Green - OK
- Red - Over current
- Amber - Low voltage

SPECIFICATION

- 12/24 volt operation
- 100 Amps total output
- Spec 5 approved
- e-approved

Software Operational Modules

100 WATT SIREN

- Supports 8 or 11 Ohm speakers
- Can be enabled from an input or handset
- Air horn input
- HRT positive or negative activation
- Multiple siren tones selected from software
- Monitor signal active when siren on
- PA and radio re-broadcast facility
- UK and European sounds
- City Mode volume reduction feature
- Workshop mode volume suppression feature for testing
- Can be linked with other MCS siren devices to give two vehicle effect

LOAD SHEDDING MODULE

- Via internal or external monitoring
- Automatic in conjunction with other equipment activation

FAN CONTROL MODULE

- Control up to 4 intake/extractor fans
- Reverses power supply to fans
- Optional 4-way Relay Expansion Module

SALOON LIGHTING MODULE

- Ideal to control internal ambulance lighting
- Manual, semi and full automatic operation

CABINET ANTI-TAMPER MODULE

- Monitor 16 ambulance medical lockers
- Ideal for monitoring medical consumables/medicines
- Cabinet re-stock indication

AUDIO INTERCOM CONTROLLER

- (operates with external device)
- Announce pre-recorded messages
 - Duplex or simplex intercom

SPLIT CHARGE CONTROLLER

- Monitors primary battery voltage
- Output drives charging solenoid to charge secondary battery
- Solenoid in and out voltage programmable

RUN LOCK CONTROLLER

- Outputs
 - 3 dedicated run lock outputs (2 with diodes)
 - Additional outputs assigned from software
- Enable Inputs
 - Inputs assigned in software
 - From handset, handbrake, remote button etc.
 - Hi or Lo inputs
- Reset Inputs
 - Inputs assigned in software
 - From brake light, remote button etc.
 - Hi or Lo inputs

HEADLIGHT FLASH

- Dedicated outputs x 4 (with built-in diodes) to control headlights and/or complementary flashing lamps

GATEWAY RADIO CONTROLLER

- Automatically switches between the Main & Gateway Radio (for built-up areas) within a 30 second window for the driver to exit the vehicle
- Automatic handbrake detection

ADDITIONAL FEATURES

- 16 x AND logic modules
- 16 x OR logic modules
- 32 x timer modules (1 second increments)

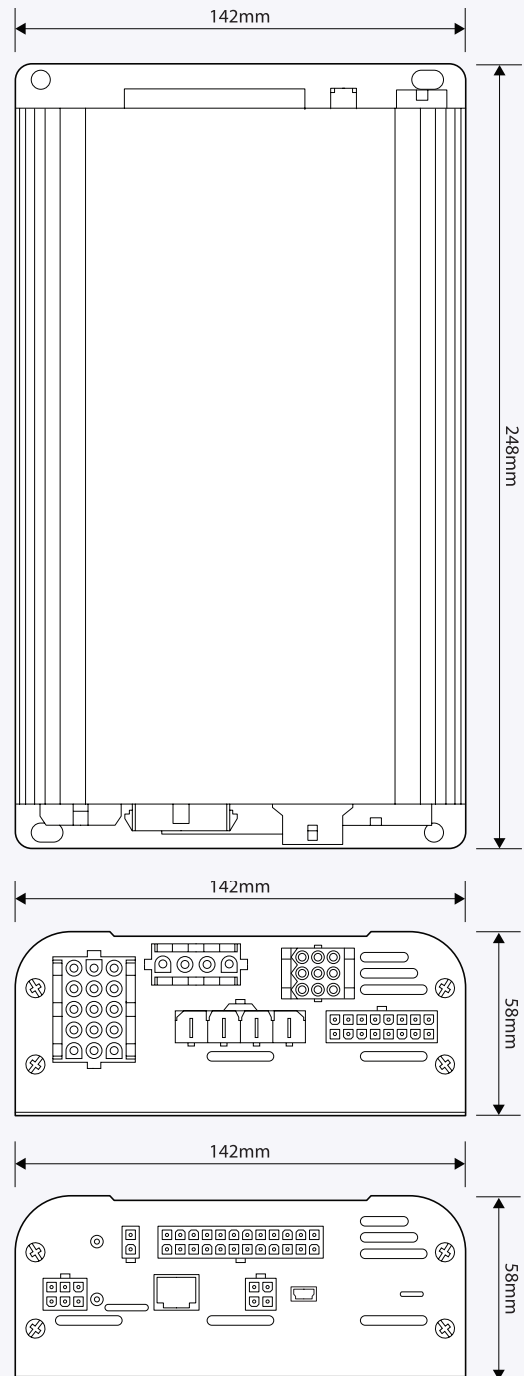
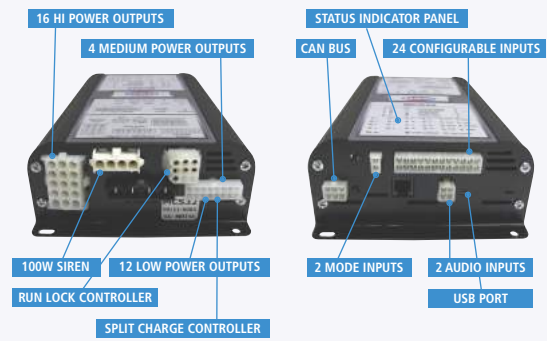

Compatible with the full range of:
Universal Multi-Way Handsets and Switch Panels
 as well as **Cyclic, Momentary and Latching Switches**

See page 7:64-7:65

for typical system specifications

MCS-32S Slave Unit

A device to expand the input and output functions of the MCS-32 Control Unit

PRODUCT OVERVIEW

The MCS-32S Slave Unit is effectively a duplicate of the standard MCS-32 which would act as its 'Master' Control Unit.

The Slave unit therefore replicates most of the 'Masters' features and functions, but not all of them as this would not be practical to achieve when one device is subordinate to the other.

In brief the Slave unit has 32 outputs and 24 configurable inputs combined with siren functions.

The features not included in this device, because practically they can only be performed by the 'Master' Control Unit are: Run Lock, Split Charging, Gateway Radio Controller, PA & Radio Re-broadcast and connection to the Audio Interface Controller.

Operation and monitoring of the 'Slave' Controller is executed through a 2-Way proprietary CAN Bus data link with the 'Master' Control Unit. Therefore as the 'Slave' only accepts proprietary CAN there is no direct monitoring of vehicle CAN signals.

System Intelligence

Although the 'Slave' unit has some self contained intelligence the 'Master' control unit has overall command of the system. Also where as the 'Master' is supplied with pre-set-up standard default settings the 'Slave' will effectively be supplied as a clean device and that would need programming via a dedicated USB port using the free complimentary PC software.

Human Machine Interface (HMI)

This will be exclusively via the 'Master' control unit as the 'Slave' has no facility to connect with our range of Multi Functional switch panels/handsets. However, discrete switches for Human Interface and/or Machine Trips can be connected into the relevant inputs if required.

One Source, One Solution

In order to simplify the installation process each unit is supplied fully loaded with all the necessary features and functions to implement a comprehensive system. Simply enable the required function via the 'easy to use' software.

Logic Functions

Like the 'Master' unit the 'Slave' also contains an abundance of logic functions meaning complex applications are no longer difficult to implement, particularly where certain operations are interlinked with other functions. So performing 'and/or' functions and implementing 'do this when' or 'stop this when' are simple to apply together with the facility to alter functions allowing 'end user' requests to be simply implemented.

System Configuration

As with the 'Master' units this is a simple 3-Stage process which entails enabling and labelling inputs and outputs, configuring the system operation and downloading the application onto the unit. This operation need only be done once, when completed it can simply be transferred onto other units via a laptop.



MCS-32S COMPONENTS

PART NO.	DESCRIPTION
UNI-SLV-002	MCS-32S Control Unit without Siren, 12/24v
UNI-PRO-002	Universal MCS Software CD
ACC-256	MCS Programming Lead and CD

MCS-32 MASTER & MCS-32S SLAVE COMPARISON CHART

FEATURES & FUNCTIONS	UNIVERSAL CONTROLLER PLUS (MCS-32)	UNIVERSAL CONTROLLER PLUS (MCS-32S)
	MASTER	SLAVE
Outputs	32	32
Inputs	24	24
Multi-Way Switches	Yes	No
Discrete Switches	Yes	Yes
Serial Data Port	Yes	No
Vehicle CAN	Yes	No
Headlight Flash	Yes	Yes
100 Watt Siren	Yes	No
Load Shedding	Yes	Yes
Fan Control	Yes	Yes
Saloon Lights	Yes	Yes
Cabinet Anti-Tamper	Yes	Yes
Audio Intercom	Yes	No
Split Charge Controller	Yes	No
Run Lock Controller	Yes	No
User Interface	Yes	Yes
Logic & Timer Modules	Yes	Yes

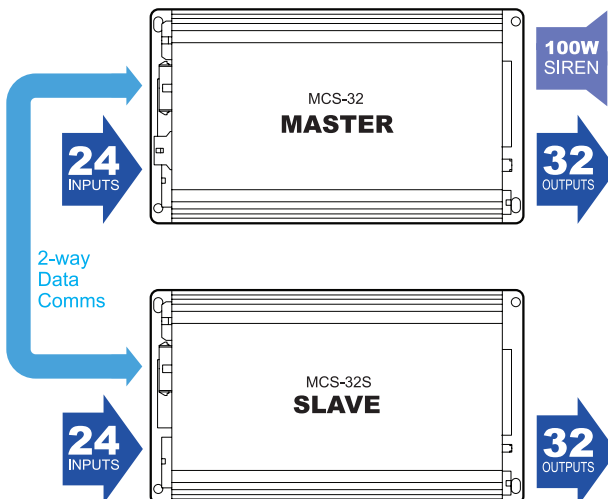

General Features and Functions

OUTPUTS

32 Outputs:

- 16 Hi Power Outputs
 - 20 Amps per channel (80 Amps total)
 - Current limiting
 - Multi flash patterns
 - Timer shutdown
 - Voltage drop out
- 12 Low Power Outputs
 - 600mA per channel
 - Positive & Negative polarity switching
 - Provide monitoring signal inputs (not high impedance)
 - Negative polarity to switch low power relays
- 4 Medium Power Outputs
 - 2.5 Amps per channel
 - Positive & Negative polarity switching
 - Provide monitoring signal inputs
 - Drive relays
 - Small motors
- 2 diode pairs built in for headlight and/or tail light flashers

INPUTS

- 24 Configurable Inputs
 - 12 negative switching
 - 12 positive switching
 - Software configurable
 - External reset
 - Standby input
- 2 Standard Inputs
 - Reset
 - Standby
- There are no audio inputs available on this device

HANDSET CONFIGURATION

- There is no facility to provide this function as this is performed solely by the MCS-32 Master Control Unit

USER INTERFACE

- 24 illuminated status indicators
- Indicates status of some internal functions, but not all as these will be available on the MCS-32 Master Control Unit
- Communication status
- Provides output status
- Green - OK
- Red - Over current
- Amber - Low voltage



Cable, Connector, Adaptor and Pin Kit

Software Operational Modules

LOAD SHEDDING MODULE

- Via internal or external monitoring
- Automatic in conjunction with other equipment activation

FAN CONTROL MODULE

- Control up to 4 intake/extractor fans
- Reverses power supply to fans
- Optional 4-way Relay Expansion Module

SALOON LIGHTING MODULE

- Ideal to control internal ambulance lighting
- Manual, semi and full automatic operation

CABINET ANTI-TAMPER MODULE

- Monitor 16 ambulance medical lockers
- Ideal for monitoring medical consumables/medicines
- Cabinet re-stock indication

AUDIO INTERCOM CONTROLLER

- This function is not available on this device as it is performed solely by the MCS-32 Master Control Unit

SPLIT CHARGE CONTROLLER

- This function is not available on this device as it is performed solely by the MCS-32 Master Control Unit

RUN LOCK CONTROLLER

- This function is not available on this device as it is performed solely by the MCS-32 Master Control Unit

HEADLIGHT FLASH

- Dedicated outputs x 4 (with built-in diodes) to control headlights and/or complementary flashing lamps

ADDITIONAL FEATURES

- 16 x AND logic modules
- 16 x OR logic modules
- 32 x timer modules (1 second increments)

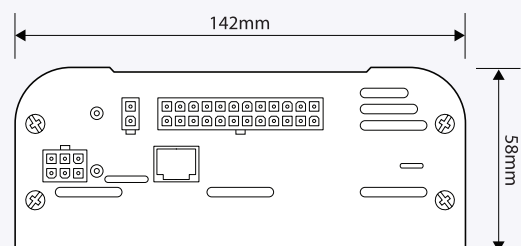
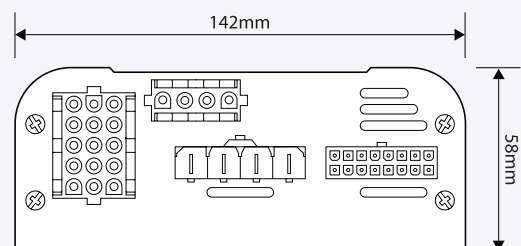
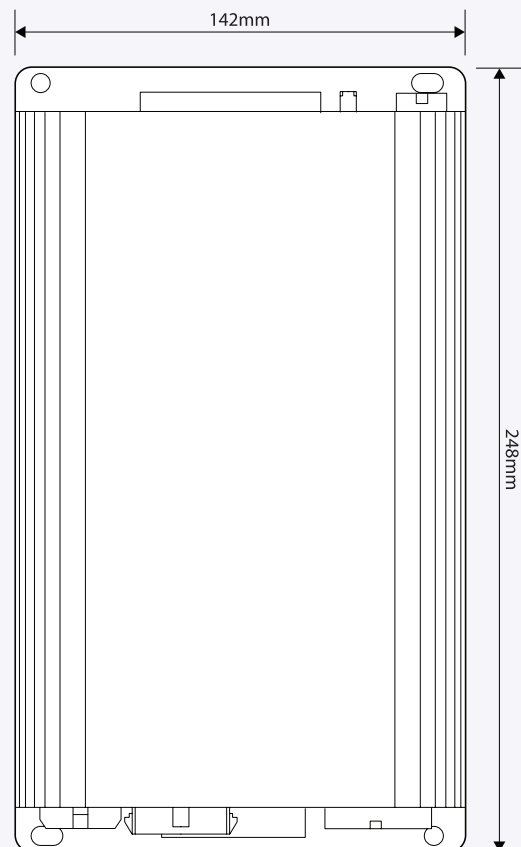
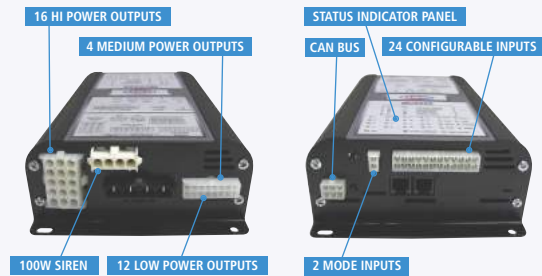

See page 7:64-7:65

for typical system specifications

General Features and Functions

OUTPUTS

16 Outputs:

- 8 High Power Outputs
 - 20 Amps per channel
 - Current limiting
 - Multi flash patterns
 - Timer shutdown
 - Voltage drop out
- 4 Low Power Outputs
 - 600mA per channel
 - Positive or Negative polarity switching
 - Provide monitoring signal inputs
 - Negative polarity to switch low power relay
- 4 Medium Power Outputs
 - 2.5 Amps per channel
 - Positive & Negative polarity switching
 - Provide monitoring signal inputs
 - Drive relays
 - Small motors
- 2 diode pairs built in for headlight and/or tail light flashers
- Output to data logger
- Electronic Fuses
 - Electronically adjustable
 - Electronically tripped

INPUTS

- 16 Configurable Inputs
 - 8 negative switching
 - 8 positive switching
 - Software configurable
 - External reset
 - Standby input
- 3 standard Inputs
 - Mic input
 - Reset
 - Standby

MULTI-WAY SWITCH OPTIONS

- Universal Multi-Way handset can be fully configured using the MCS software
- Single or up to 4 handsets

SERIAL DATA PORT

- USB x 1
- Link with third party MDT terminals

CAN OR CAN TYPE DATA PORT

- Link to Standby RSG complementary devices such as a lightbar
- Link to other industry new standard devices - CAN Bus
- Link with legacy equipment - PWM

USER INTERFACE

- 24 illuminated status indicators
- Indicates flash pattern
- Communication status
- Provides output status
- Green - OK
- Red - Over current
- Amber - Low voltage

SPECIFICATION

- 12/24v operation
- 100 Amps total output
- Spec 5 approved
- 12v version only e-approved

Software Operational Modules

100 WATT SIREN

- Supports 8 or 11 Ohm speakers
- Can be enabled from an input or handset
- Air horn input
- HRT positive or negative activation
- Multiple siren tones selected from software
- Monitor signal active when siren on
- PA
- UK and European sounds
- City Mode volume reduction feature
- Workshop mode volume suppression feature for testing
- Can be linked with other MCS Siren devices to give 2 vehicle effect

LOAD SHEDDING MODULE

- Via internal or external monitoring
- Automatic in conjunction with other equipment activation

FAN CONTROL MODULE

- Control up to 4 intake/extractor fans
- Reverses power supply to fans
- Optional 4-way relay expansion module

SALOON LIGHTING MODULE

- Ideal to control internal ambulance lighting
- Manual, semi and full automatic operation

CABINET ANTI-TAMPER MODULE

- Monitor 16 ambulance medical lockers
- Ideal for monitoring medical consumables/medicines
- Cabinet re-stock indication

AUDIO INTERCOM CONTROLLER

(operates with external device)

- Announce pre-recorded messages
- Duplex or simplex intercom

SPLIT CHARGE CONTROLLER

- Monitors primary battery voltage
- Output drives charging solenoid to charge secondary battery
- Solenoid in and out voltage programmable

RUN LOCK CONTROLLER

- Outputs
 - 1 dedicated run lock output
 - Additional outputs assigned from software
- Enable Inputs
 - Inputs assigned in software
 - From handset, handbrake, remote button etc.
 - Hi or Lo inputs
- Reset Inputs
 - Inputs assigned in software
 - From brake light, remote button etc.
 - Hi or Lo inputs

HEADLIGHT FLASH

- Dedicated outputs x 2 (with built-in diodes) to control headlights and/or complementary flashing lamps

GATEWAY RADIO CONTROLLER

(operates with external device)

- Automatically switches between the Main & Gateway Radio (for built-up areas) within a 30 second window for the driver to exit the vehicle
- Automatic handbrake detection

ADDITIONAL FEATURES

- 16 x AND logic modules
- 16 x OR logic modules
- 32 x timer modules

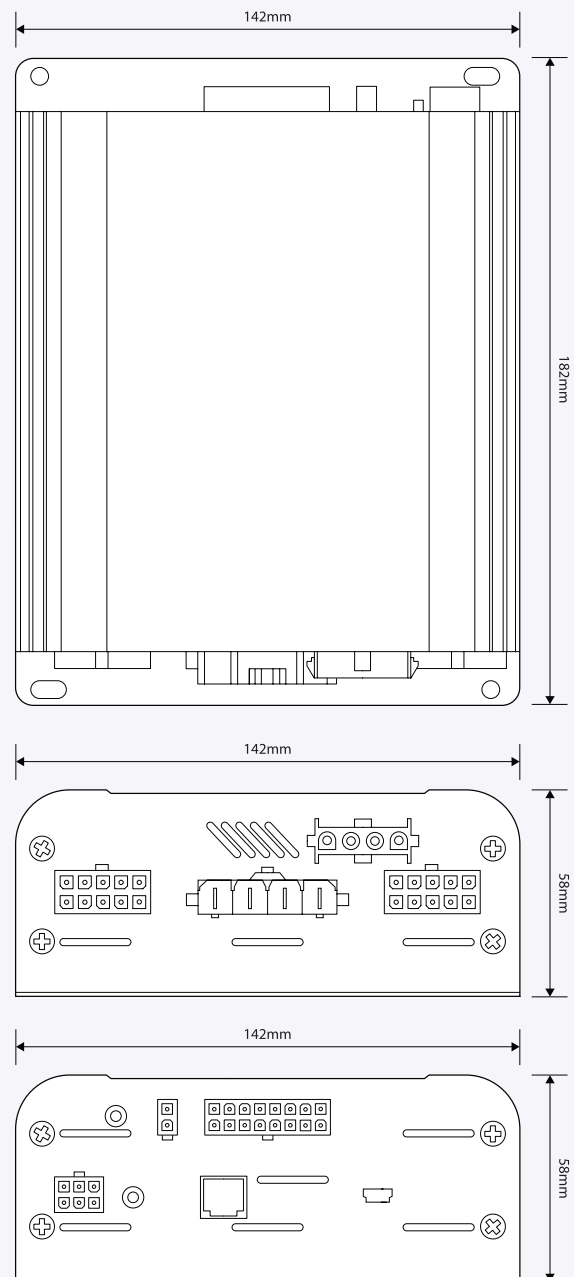
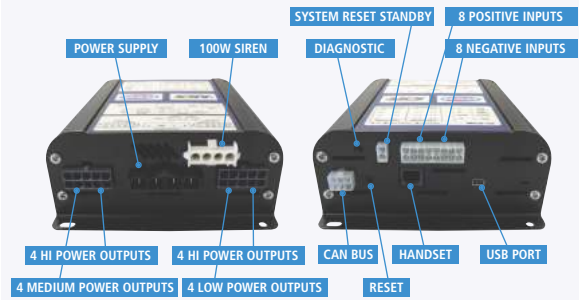

2:15

Section 2 : MCS Control Units

Compatible with the full range of:
Universal Multi-Way Handsets and Switch Panels
 as well as **Cyclic, Momentary and Latching Switches**

See page 7:64-7:65

for typical system specifications

MCS-8 Control Unit

For the operation of vehicle rooftop lighting, secondary lighting and power management

PRODUCT OVERVIEW

The MCS-8 Control Unit consists of a main control box which contains everything required to control a 'complete but optimised' vehicle mounted hazard warning system, typically comprising of a rooftop lightbar, secondary hazard warning lights and audio equipment. It has 4 high power outputs, 4 dual purpose inputs and medium power outputs and 6 dedicated inputs. It also includes power management functions including run lock, split charging, load shedding and headlight flash, plus many more, some of which may be implemented by listening in to the vehicle CAN Bus system. It also includes a logic switch module to facilitate control of auxiliary add-on devices such as: Gateway Radio Controller, Audio Interface Controller (Intercom with pre-recorded 'voice' alerts) and Fan Controller.

Operate the controller through one of our range of fully compatible hand held or dash mounted switch units and you have an economical hazard warning control system that does not compromise on features and functions.

System Intelligence

The MCS-8 is usually supplied as an unprogrammed unit as free PC software for setting up unique configurations, user manuals and training are available on request. Also once a satisfactory configuration has been created it can be transferred to any number of units by use of a laptop.

Human Machine Interface

We have developed a collection of switch units specifically designed to interface with the MCS-8. They range from a 5 button handset to a 20 button flush mount unit. Handsets have the facility to operate a Public Address (PA) system via an integral microphone and the option to allocate any button to operate the Push to Talk (PTT) feature.

One Source, One Solution

In order to simplify the installation process each unit is supplied fully loaded with all the necessary features and functions to get a comprehensive system implemented. Simply enable the required functions via the 'easy to use' software.

Logic Functions

An abundance of logic functions means complex applications are no longer difficult to implement, particularly where certain operations are interlinked with other functions. So performing and/or functions and implementing 'do this when' or 'stop this when' are simple to apply together with the facility to alter functions allowing requested client updates to be simply implemented.

System Configuration

This is a simple 3-Stage process which entails enabling and labelling inputs and outputs, configuring the system operation and downloading the application onto the unit. This operation need only be done once, when completed it can be simply be transferred onto other units via a laptop.



OPTIONAL BUILT-IN SIREN!



Cable, Connector, Adaptor and Pin Kit

MCS-8 COMPONENTS

PART NO.	DESCRIPTION
UNI-EIG-001	MCS-8 Control Unit with Siren, 12/24v
UNI-EIG-002	MCS-8 Control Unit without Siren, 12/24v
UNI-PRO-002	Universal MCS Software CD
ACC-256	MCS Programming Lead and CD

General Features and Functions

OUTPUTS

8 Outputs:

- 4 High Power Outputs
 - 20 Amps per channel - see current ratings
 - Current limiting
 - Multi flash patterns
 - Timer shutdown
 - Voltage drop out
- Medium Power Outputs
 - 2.5 Amps per channel
 - Positive or Negative switching (configurable via software)
 - Can also be used as inputs
 - Ideal for monitoring or special functions
 - Drive relays
 - Small motors
 - Monitor outputs
- 1 diode pair built in for headlight and/or tail light flashers
- Output to data logger
- Electronic Fuses
 - Electronically adjustable
 - Electronically tripped

INPUTS

10 Inputs:

- 6 Dedicated and 4 Shared Inputs
 - 10 Positive Inputs (Configurable as negative via software)
 - Software configurable

MULTI-WAY SWITCH OPTIONS

- Universal Multi-Way handset can be fully configured using the MCS software
- Single or up to 4 handsets

SERIAL DATA PORT

- USB Programming Port

CAN DATA PORT

- Listen in to Vehicle CAN Bus
- Link to Standby RSG complementary devices such as a lightbar
- Link to other industry new standard devices
- Link with legacy equipment

LIN BUS SUPPORT

- Optional LIN Bus compatible devices

USER INTERFACE

- 16 illuminated status indicators
- Indicates flash pattern
- Communication status
- Provides output status when applicable
- Green - OK
- Red - Over current
- Amber - Low voltage

CURRENT RATINGS

- Complete system 50 Amps (including 7 Amps for siren operation)
- Bank A: 40 Amp (Siren, Hi Power O/P 1, Low Power, O/P's 1 and 2)
- Bank B: 40 Amp (Siren, Hi Power O/P's 3 and 4, Low Power, O/P's 3 and 4)
- Bank P: 20 Amp (Hi power output 2)

SPECIFICATION

- 12/24v operation

Software Operational Modules

100 WATT SIREN (OPTIONAL)

- Supports 8 or 11 Ohm speakers
- Can be enabled from an input or handset
- Air horn input
- HRT positive or negative activation
- Multiple siren tones selected from software
- Monitor signal active when siren on
- PA and radio re-broadcast facility with adjustable volumes
- UK and European sounds
- City Mode volume reduction feature
- Workshop mode volume suppression feature for testing
- Sounds when low voltage detected (optional)

LOAD SHEDDING MODULE

- Via internal or external monitoring
- Automatic in conjunction with other equipment activation

FAN CONTROL MODULE

- Control up to 4 intake/extractor fans
- Reverses power supply to fans

SALOON LIGHTING MODULE

- Ideal to control internal ambulance lighting
- Manual, semi and full automatic operation

CABINET ANTI-TAMPER MODULE

- Monitor 16 ambulance medical lockers
- Ideal for monitoring medical consumables/medicines
- Cabinet re-stock indication

AUDIO INTERCOM CONTROLLER

(operates with external device)

- Announce pre-recorded messages
- Duplex or simplex intercom

SPLIT CHARGE CONTROLLER

- Monitors primary battery voltage
- Output drives charging solenoid to charge secondary battery
- Solenoid in and out voltage programmable

RUN LOCK CONTROLLER

- Outputs
 - Run Lock outputs assigned in software (diodes to be fitted as required)
- Enable Inputs
 - Inputs assigned in software
 - From handset, handbrake, remote button etc.
 - Hi or Lo inputs
- Reset Inputs
 - Inputs assigned in software
 - From brake light, remote button etc.
 - Hi or Lo inputs

HEADLIGHT FLASH

- Dedicated outputs (with built-in diodes) to control headlights and/or complementary flashing lamps

GATEWAY RADIO CONTROLLER

- Automatically switches between the Main & Gateway Radio (for built-up areas) within a 30 second window for the driver to exit the vehicle
- Automatic handbrake detection

ADDITIONAL FEATURES

- 16 x AND logic modules
- 16 x OR logic modules
- 32 x timer modules

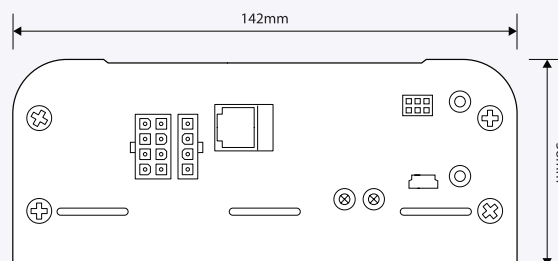
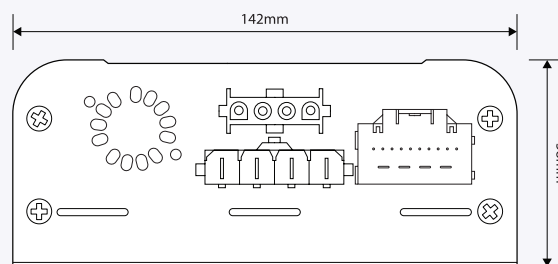
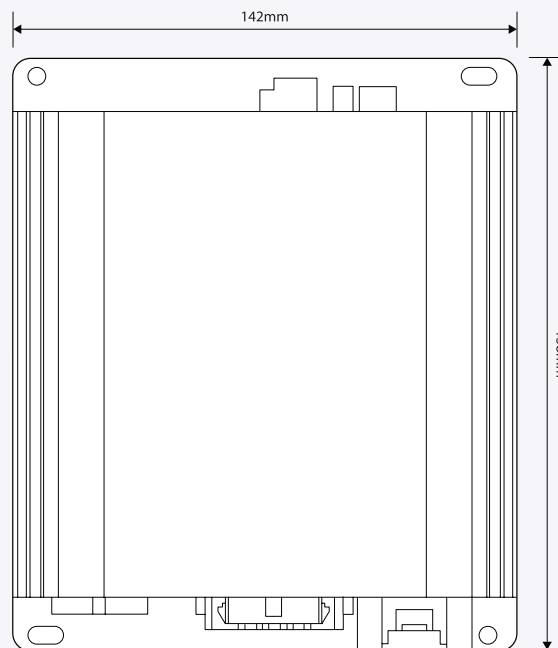
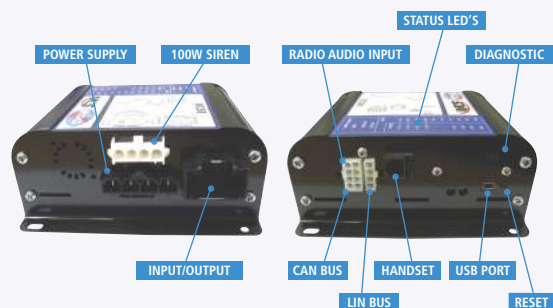

See page 7:64-7:65

for typical system specifications

Compatible with the full range of:
Universal Multi-Way Handsets and Switch Panels
 as well as **Cyclic, Momentary and Latching Switches**

MCS-H16 Control Unit

Multi-functional control and/or expansion module to operate as a master or as slaves

PRODUCT OVERVIEW

The high powered MCS-H16 can be configured for use as a single stand alone master controller or ganged up with other H16 units set up as slaves. Alternatively it can be used as a heavy duty expansion unit alongside a MCS-32, MCS-16 or MCS-8 control unit.

Although the MCS-H16 was primarily designed to be a high powered expansion unit (up to 120 Amps) for use with our popular range of MCS control units it is also extremely effective as a stand alone unit or ganged up with multiple units. This makes it ideal for use in larger installations where system intelligence is provided by an MCS-32, MCS-16 or MCS-8 and system expansion via the MCS-H16.

Device Outputs

Each MCS-H16 has:

- **12 Outputs**
Channels 1-12 are organised as 3 banks (A, B and C) of 4 Outputs. Each output can deliver 20 Amps and where the total for each group (A, B or C) collectively is 40 Amps each
- **2 High Current Outputs**
Channels 13 and 14 are dual polarity drivers capable of driving 40 Amps each, suitable for bi-directional motor control
- **2 Outputs**
Channels 15 and 16 are coupled outputs capable of driving 40 Amps each

Application Options

- Single MCS-H16 unit - Set up as a Master
- Single MCS-H16 unit - Set up as a Slave
- Multiple MCS-H16 units - Set 1 up as master, others as slaves
- Multiple MCS-H16 units - Set all up as slaves
- Single MCS-H16 unit + MCS-32 - Set all up as slaves
- Single MCS-H16 unit + MCS-16 - Set all up as slaves
- Single MCS-H16 unit + MCS-8 - Set all up as slaves

Note: Units can be supplied either set up as a Master or Slave unit. However, as with other MCS devices customers will be able to create their own configuration settings, and where for large volume applications Standby RSG can apply this pre-shipping and will allocate a unique part number. Also note the current available firmware can only support a gang of two Slaves, therefore if more are required bespoke firmware can be supplied by discussing specific applications with our technical department.

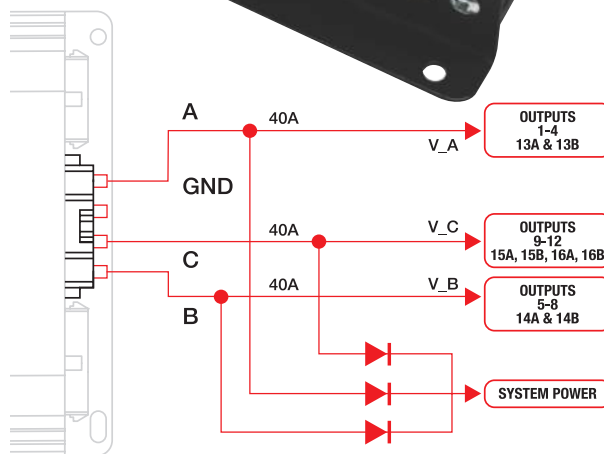

Cable, Connector, Adaptor and Pin Kit

MCS-16 COMPONENTS

PART NO.	DESCRIPTION
UNI-HPC-002	MCS-H16 High Power Control Unit, 12/24v
UNI-SLV-H16	MCS-H16 Slave High Power Control Unit, 12/24v
22-1449	Senior Fit Female
22-1421	Mini Fit Female
22-1423	Mate 'n' Lock Female
45-1733	Molex Crimp Tool - Mini Fit Junior
UNI-PRO-002	Universal MCS Software CD
ACC-256	MCS Programming Lead and CD



MULTIPLE MCS-H16

MCS-H16 & MCS-16

General Specification

Absolute Maximum Ratings

Supply Voltage: 32 Volts DC
Supply Current: 40 Amps per Power Bank A, B & C

Electrical Characteristics

Operating Voltage: 12 to 24 Volts DC
Current Consumption:

Running: 50.0 Milliamps @ 13.8VDC
no peripherals attached
Idle: 12.8 Milliamps @ 13.8VDC
no peripherals attached
Running: 38.5 Milliamps @ 27.6VDC
no peripherals attached
Idle: 10.0 Milliamps @ 27.6VDC
no peripherals attached

Temperature

Standby Temperature: -20°C to +70°C
Operating Temperature: -20°C to +50°C

Power

3 x 40Amp DC pins on pluggable connector - Banks A, B & C

Note: These 'MUST' be fused with 40Amp fuses or less depending on application

1 x Ground/Chassis Connections

Digital Inputs

4 x Positive Switched

Analog Inputs

3 x Analog Inputs

Analog Monitoring

Bank A Voltage Sense
Bank B Voltage Sense
Bank C Voltage Sense
Internal Temperature Monitor
Output Channel Current Monitors

Outputs

12 x High side current and voltage protected outputs - 20 Amp per channel with a limit of 40 Amp for each Bank (A, B or C)

2 x High side current and voltage protected outputs - 40 Amp per channel with a limit of 40 Amp for each Bank (A, B or C)

2 x Bi-Polar current and voltage protected outputs - 40 Amp per channel with a limit of 40 Amp for each Bank (A, B or C)

Communications

1 x RS485 Communication for remote handheld interface & for Slave Siren connection

1 x LIN Bus - Future proof connection

2 x CAN Bus 2.0. 1 x for local CAN Bus connections to other compatible devices and another for bespoke vehicle communications via monitoring suitable CAN Bus signals

System Description

High Power Outputs

There are 12 positive switching outputs:

- The first 4 channels are banked collectively as Group A, and the second 4 channels are banked collectively as Group B and the last 4 channels are banked collectively as Group C.
- Each of these 12 outputs is independently capable of switching 20 Amps.
- Group A, B and C can source a maximum of 40 Amps each.
- Each channel can be programmed with individual over-current and under voltage protection.
- Channel 15 and 16 are coupled outputs capable of driving 40A each.
- Channel 13 and 14 are half bridge drivers also capable of driving 40A each.

Using the standard MCS Configurator software, the outputs can be configured for:

- Minimum Voltage Dropout. (Disables the output when the supply voltage drops below the set level)
- Maximum Current Protection (Disabled the output when the output current exceeds the set current level for a time period)
- Output Mode - A selection of flashing patterns is available:
 - Steady On
 - Alternating
 - Multi Flash
 - Penta Pulse
 - Penta Pulse (With Pause)
 - Cyclic
 - Arrow\Direction
 - Double Flash
- Mode Levels - each output has 3 Mode level which define a priority level for the selected switching conditions
 - Mode Level 1 - Takes highest priority
 - Mode Level 2 - Takes priority over Mode Level 3
 - Mode Level 3 - Is the lowest priority
- Enable Inputs
 - Up to 8 inputs can be selected to enable (turn on) the output. If 'ANY' of the enable inputs is active, the output can turn on.
- Inhibit Inputs
 - Up to 4 inhibit inputs can be selected the inhibit the output. If 'ANY' of the inhibit inputs is active, the output will not be turned on. Inhibits take precedence over 'Enables'

Diagnostics and Troubleshooting

16 x Diagnostic LED's on the upper side of the unit that are used to assist installers and users to find faults and/or operational issues

- 1 x LED Power Monitoring
- 2 x LED's for CAN Port Monitoring
- 13 x LED's for monitoring Inputs and Outputs

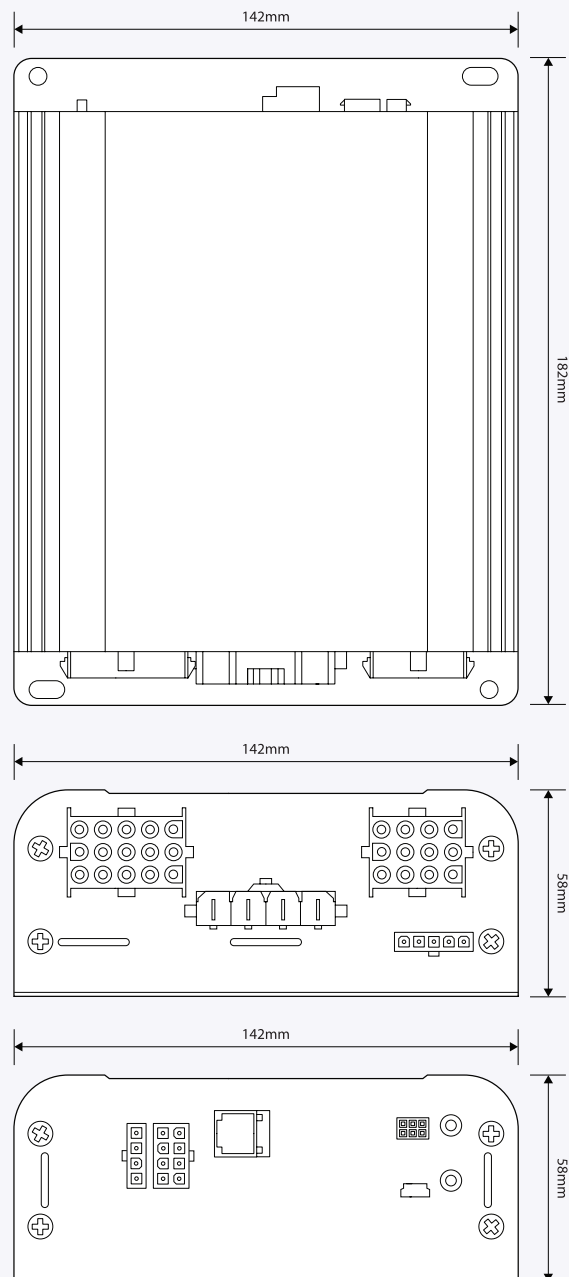
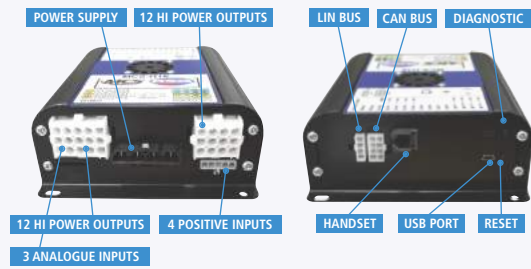

Compatible with the full range of:
Universal Multi-Way Handsets and Switch Panels
as well as **Cyclic, Momentary and Latching Switches**

Section 3 :

MCS Expansion Units

In the event that the MCS-32 Control Unit does not contain sufficient functions in its own right, additional expansion units can be added to substantially increase operating capacity.

We have various expansion units for a variety applications including:

MCS-5E Load Switch

A device that can expand the input and output functions of a MCS Control Unit, be used as a stand-alone control device or linked with the MCS-SE Siren to create a basic hazard warning system.

Compatible with the full range of MCS Control Units the MCS-5E increases outputs by 5 and inputs by potentially 7. When used in conjunction with a siren it provides a cost effective emergency services system.

See page 3:21 for product specifications.



Lighting Breakout Controllers

Lighting Breakout Controllers are used to expand the input and output functions of a MCS Control Unit.

These devices can be fitted within a lightbar to convert from a multi-wired input to a two wired CAN Bus input, as a light head breakout box to create nodes elsewhere in the vehicle or as a low cost control head to expand MCS systems.

See pages 3:22 - 3:23 for product specifications.

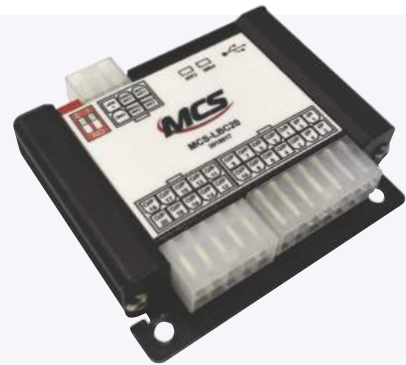

CAN Bus Interface Modules

CAN Bus Interface Modules extract/monitor information from the vehicle CAN Bus system.

By extracting information from the vehicle CAN Bus system interface modules can either convert the information into a set-up of conventional on/off signals or convert discreet on/off signals to a CAN Bus data stream to feed into a devices CAN Bus data port.

See pages 3:24 - 3:25 for product specifications.



CAN Bridge Devices

Have unique firmware that provide a link from various MCS Units to either a third party lightbar or Mobile Data Terminal (MDT).

CAN Bridge devices form a bridge between a MCS CAN Bus connection and a CAN Bus port on another manufacturers lightbar or MDT equipment.

See page 3:26 for product specifications.



MCS-5E Load Switch UNI-LDS-002

A device that can expand the input and output functions of a MCS Control Unit, be used as a stand-alone control device or linked with the MCS-5E 100W Siren to create a basic hazard warning system

PRODUCT OVERVIEW

One application for the MCS-5E Load Switch is to boost the inputs and outputs of a MCS-32. It is also fully compatible with the full range of MCS Control Units.

The addition of a single MCS-5E Load Switch to a MCS-32 increases outputs by 5 and inputs by potentially 7. Up to 8 Load Switches can be added increasing the maximum amount of outputs from 32 to 72 and inputs potentially from 24 to 80.

This device is also ideal as a control hub for basic blue or amber hazard warning lighting systems. When used in conjunction with a siren it provides a cost effective emergency services system.

As well as having 4 operating modes depending upon the application, it also has two CAN Bus ports to allow multiple units to be linked together and/or linkage to other devices such as switch panels and sirens with CAN Bus connections, including Standby RSG's range of MCS Control Units.

• 4 Multi Functional Operating Modes

Simply selected via DIP switches to get:

Mode 1 - 5-way solid state relay pack

Mode 2 - Headlight flasher, run lock and single solid state relay

Mode 3 - Headlight flasher and 3 solid state relays

Mode 4 - Run lock and 3 solid state relays

• Independently Settable Over Current Protection

- Each solid state relay channel can have it's current limit independently set to 5, 10, 15 or 20 amps via DIP switches, ideal for load management applications
- Eliminates the need for external low current fusing per channel.

Only a single high current fuse is required

• Under voltage protection

- This feature can be enabled and disabled via a single DIP switch. When enabled, outputs are inhibited when the supply voltage drops below 12.1 volts

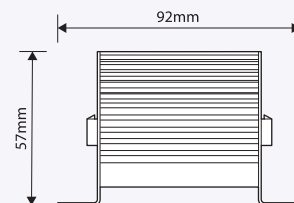
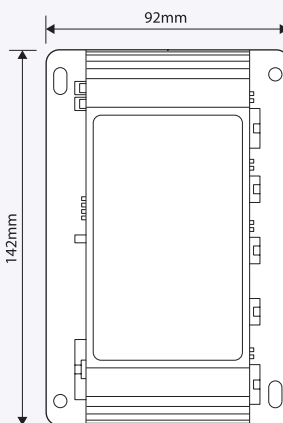
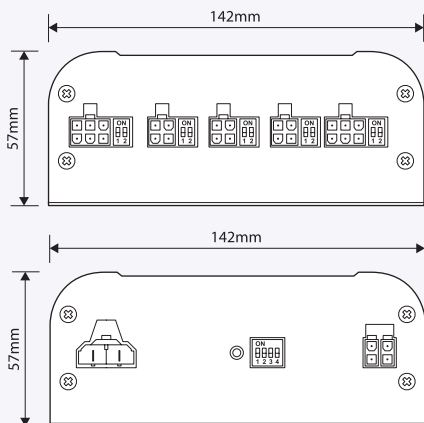

See page 7:65 for typical system specifications

MCS-LBC10 High Current Lighting Breakout Controller

A higher current device that can expand the input and output functions of a MCS Control Unit or be used in conjunction with other MCS devices to convert/increase inputs and outputs

PRODUCT OVERVIEW

One application of the MCS-LBC10 Lighting Breakout Controller is to boost the inputs and outputs of a MCS Control Unit.

The MCS-LBC10 Lighting Breakout Controller takes a CAN Bus encoded signal and converts it into a set of up to 10 conventional on/off (12 volts on and 0 volts off) signals to turn lights and/or other control units on and off.

By connecting a Lighting Breakout Controller to a MCS-32 you add 10 outputs, thereby increasing the outputs from 32 to 42. The inputs are also increased by 4 making a total of 28 inputs.

Measuring 78mm x 105mm and only 30mm deep the unit can fit almost anywhere including such applications as:

- Inside a lightbar to convert from multi wired input to two wired CAN Bus input (plus positive and negative connections)
- Light head 'Breakout Box' to create nodes at front, rear or elsewhere in the vehicle
- Low cost control head to expand systems based on other MCS devices that would typically be the MCS-LDS Load Switch or MCS-SE 100W Siren

Absolute Maximum Ratings

- Supply Voltage: 32 Volts DC
- Supply Current: 40 Amps

Electrical Characteristics

- Operating Voltage: 12-24 Volts DC
- Current Consumption:
 - Typical: 50 milliamps. (@13.8VDC, no peripherals attached)
 - Max: 60 milliamps. (@13.8VDC, no peripherals attached)
- Temperature:
- Standby Temperature: -20 Deg C to +70 Deg C
- Operating Temperature: -20 Deg C to +65 Deg C

Below is typical connection diagrams for rear lighting control.

Typical connections to rear lights install at rear of vehicle

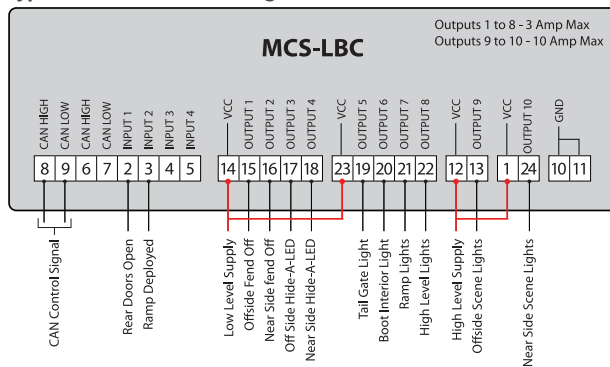

MCS-LBC10 LIGHTING BREAKOUT CONTROLLER	
PART NO.	DESCRIPTION
UNI-LBC-001	MCS-LBC10 10-Way Lighting Breakout Controller - 100KHz
UNI-LBC-002	MCS-LBC10 10-Way Lighting Breakout Controller - 200KHz

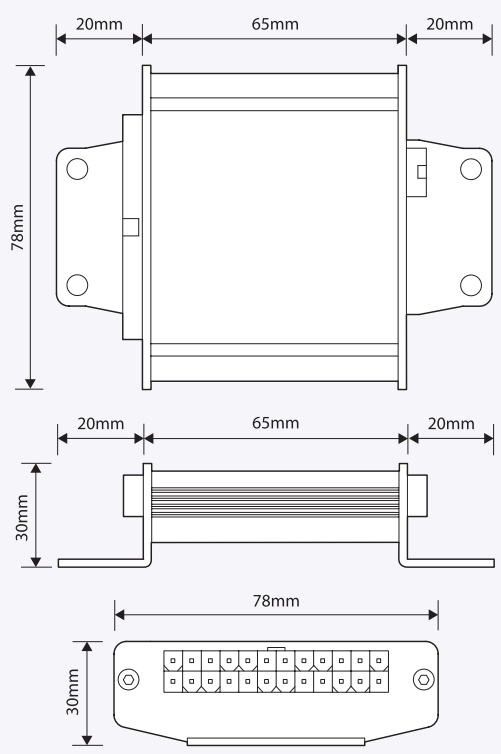

MCS-LBC20 Low Current Lighting Breakout Controller

A lower current device that can act as a CAN Bus interface between a lightbar and a MCS Control Unit or expand the input and output functions of the unit or be used in conjunction with other devices to convert/increase inputs and outputs

PRODUCT OVERVIEW

The main application of the MCS-LBC20 Lighting Breakout Controller is to operate as a CAN Bus interface between a MCS Control Unit and any traditionally switched Lightbar via a multi-colored cable (one wire per on/off function).

This device would normally be fitted within the lightbar and as such it only has 4 wired connections (+ve, -ve, CAN High and Low) making it ideal to migrate through vehicle roof rail mounting holes (points) usually found under the cosmetic concealing strip when no roof rails are fitted.

Measuring 74mm x 78mm and only 20mm deep the unit can fit almost anywhere. As well as going inside the lightbar, it is also suited to other low current applications

Absolute Maximum Ratings

- Supply Voltage: 32 Volts DC
- Supply Current: 3 Amps

Electrical Characteristics

- Operating Voltage: 12-24 Volts DC
- Current Consumption:
 - Running: 25 milliamps. (@13.8VDC, no peripherals attached)
 - Idle: 9 milliamps. (@13.8VDC, no peripherals attached)
- Temperature:
 - Standby Temperature: -20 Deg C to +70 Deg C
 - Operating Temperature: -20 Deg C to +50 Deg C



Connector and Pin Kit

MCS-LBC20 LIGHTING BREAKOUT CONTROLLER	
PART NO.	DESCRIPTION
UNI-LBC-201	MCS-LBC20 20-Way Lighting Breakout Controller - 100KHz
UNI-LBC-202	MCS-LBC20 20-Way Lighting Breakout Controller - 200KHz

1 x CAN BUS CONNECTION
POWER TO DEVICE



20 x 100 MILLIAMP OUTPUTS
250 MILLIAMPS PER OUTPUT
4 x DIGITAL INPUTS

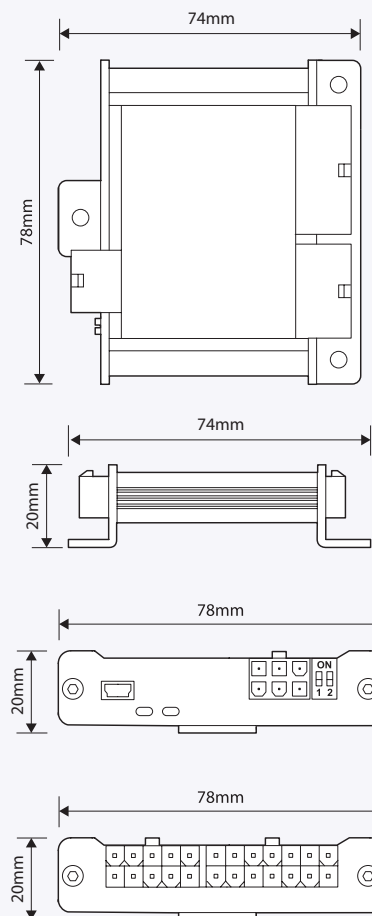

MCS-CANIO CAN Bus Interface Module

The 10-way CAN Bus Interface Module extracts and processes signals from the vehicle CAN Bus system

PRODUCT OVERVIEW

By extracting information from the vehicle CAN Bus system it converts these into a set-up of up to 10 conventional on/off (12 volts on and 0 volts off) signals to turn lights and/or other control units on and off.

Specification

- 10 x relays Drive Outputs (Total 10 Amps Max)
- Specific vehicle selected via 4-way dip switch

Typical Outputs:

- Ignition
- Sidelight
- Dip Beam
- Main Beam
- Indicator Left
- Indicator Right
- Foot Brake/Speed Levels
- Tailgate Door
- Hand Brake
- Stop Lamps
- Doors Open
- Engine Run/Alternator Charging
- Engine Crank/Starter Motor Engage

Absolute Maximum Ratings

Supply Voltage: 32 Volts DC

Supply Current: 10 Amps

Electrical Characteristics

Operating Voltage: 12 to 24 Volts DC

Standby Current: 50.0 Milliamps @ 13.8VDC

Output Drive:

Single Output: 3 Amps Max

10 x Outputs 10 Amps Max (equivalent to 1 Amp per output)

Temperature

Standby Temperature: -20 Deg C to +70 Deg C

Operating Temperature: -20 Deg C to +50 Deg C



10-WAY CAN BUS INTERFACE MODULE	
PART NO.	DESCRIPTION
UNI-CAN-003	CANIO 10-Way Unprogrammed CAN Interface Module
UNI-CAN-003-1	CANIO 10-Way Unprogrammed CAN Interface Module - Vehicle Specific
UNI-PRO-003	Software & Driver CD ROM for CANIO
KIT-259	CD Software/Driver + Programming Cable for UNI-CAN-003

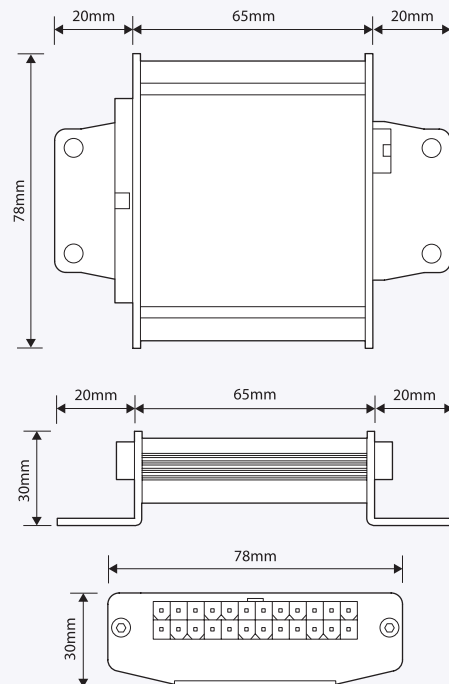

MCS-CIM CAN Interface Module

The 20-way Reverse Data Bus Interface Module monitors discreet On/Off signals and converts them to a CAN Bus Data Stream to feed into a CAN Bus Data Port

PRODUCT OVERVIEW

By monitoring On/Off (12 volts On and 0 volts Off) signals directly from vehicle functions or auxiliary equipment the unit then converts these into a data stream to feed into another devices CAN Bus data port that would typically be on a telematics device.

Ideal application

Convert an existing Standby RSG Voyager based telematics installation to a FleetMotus based solution.

Specification

- 20 x Digital Inputs
- 1 x CAN Bus Output

Typical Outputs:

- Sidelights
- Dip Beam
- Main Beam
- Indicator Left
- Indicator Right
- Foot Brake
- Hand Brake
- Doors Open
- 1st Stage Retarder
- 2nd Stage Retarder
- Ladder Rack
- Water Pump
- PTO Engaged
- Engine Run/Alternator Charging
- Engine Crank/Starter Motor Engage
- Locker Opened

Absolute Maximum Ratings

Supply Voltage: 32 Volts DC

Supply Current: 3 Amps

Electrical Characteristics

Operating Voltage: 12 to 24 Volts DC

Standby Current: 100 Milliamps @ 13.8VDC

Temperature

Standby Temperature: -20 Deg C to +70 Deg C

Operating Temperature: -20 Deg C to +50 Deg C



Connector and Pin Kit

10-WAY CAN BUS INTERFACE MODULE

PART NO.	DESCRIPTION
UNI-CIM-001	MCS-CIM CAN Interface Module

1 x CAN BUS CONNECTION
POWER TO DEVICE



20 x DIGITAL ON/OFF INPUTS
4 x SPARE INPUTS

20 x
ON/OFF
INPUTS

ON/OFF DATA SIGNALS IN

CAN OUT

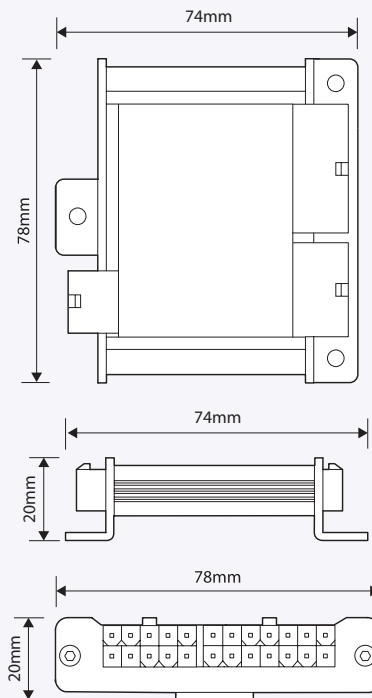

3:25

Section 3 : MCS Expansion Units

MCS CAN Bridge Devices

Modules with unique firmware that provide a link from various MCS Units (typically MCS control units and matrix displays) to either a third party lightbar or a Mobile Data Terminal (MDT). Although common hardware can sometimes be used, each application generally requires a unique firmware solution.

CAN BRIDGE TO LIGHTBARS

Links MCS devices to 3rd Party new and legacy lightbars.

A device that forms a bridge between a MCS CAN Bus connection and a CAN Bus port on another manufacturers lightbar. This is normally achieved by reverse engineering the CAN Bus signal originating from within the lightbar. Usually the co-operation of the lightbar manufacturer and/or a sample lightbar is required to perform this operation.

Typical Ratings

- Supply Voltage: 12 Volts DC
- Supply Current: 50mA
- Standby Temperature: -20 Deg C to +70 Deg C
- Operating Temperature: -20 Deg C to +65 Deg C

CAN BRIDGE TO MOBILE DATA TERMINALS (MDT's)

Links MCS devices to 3rd Party new and legacy Mobile Data Terminal (MDT) equipment

A device that forms a bridge between a MCS CAN Bus connection and a CAN Bus port on another manufacturers MDT equipment. This is normally achieved by developing special firmware such that the two CAN Bus protocols can exchange information with each other. As Standby RSG has no means to interrogate the CAN Bus signal originating from within the MDT device, to perform this function the co-operation of the MDT manufacturer is essential. To assist with the MCS CAN Bus format which they can normally interpret with minimal assistance.

Description	Application	Part Number
MCS-MDT-CANBRIDGE Telematics and Remote Control Interface with USB A connection	OPSES Impero (Post 1st Nov 19)	UNI-BRI-003
Terrafix TVC4000 with MHE Windows based Remote Control application installed on TVC system	MCS-Bridge. MDT Interface with USB A connection	UNI-BRI-005



Description	Application	Part Number
MCS-CAN-BRIDGE Lightbar Interface with CAN connection	Interface for non-Standby RSG Lightbars Contact Standby RSG Technical Department for models currently supported and FREE assessment	UNI-BRI-001
MCS-CAN-BRIDGE Telematics and Remote Control Interface with CAN connection	OPSES Impero (Pre 1st Nov 19)	UNI-BRI-002



Description	Application	Part Number
MCS-CAN-BRIDGE Telematics and Remote Control Interface with DB9 connection	Attobus M-PC3 (Revised version recommended for new installations)	UNI-BRI-006
MCS-CAN-BRIDGE MDT Interface with DB9 connection	Attobus M-PC3	UNI-BRI-004



Description	Application	Part Number
MCS-SPL12 Traffic Commander Matrix Display RS232 Adaptor	Attobus M-PC3 RS232 Serial Interface for Traffic Commander Matrix Display Note: Set Matrix Display to UART over CAN	19-1517



Description	Application	Part Number
MCS-PGM RS485 to USB Programming Cable	Terrafix TVC4000 Programming Cable/RS485 Data Stream Interface USB to RS485 level converter cable	ACC-237



Thames Valley Police

Volvo V60

- MCS-32 Control Unit
- F5D Switch Unit
- Aegis LED Lightbar
- Edge Saber LED Module
- LED Number Plate Warning Light



Section 4 :

MCS Sirens & Speakers

MCS Digital and Electronic Siren Amplifiers, Loudspeakers and Complimentary Operational Devices

NEW! Digital Siren Amplifiers (Class D)

By utilising digital technology Class D Siren amplifiers have several advantages over traditional power amplifiers which rely on transformers to convert low power electronic signals into high power outputs from typically 60 to 200 Watts.

This is achieved by utilising solid state digital technology amplifiers that are more efficient in converting low power signals into higher ones together with allowing waveforms to be processed and configured to give a more noticeable and attention-grabbing audio warning sound.

As the new Class D electronic technology amplifier is fully based on solid state technology rather than a hybrid of solid state and transformer technology, as used in traditional amplifiers, the distortion associated with the audio output signal is a lot less, particularly when used as a PA amplifier.

This is due to enhanced amplifier technology processing and outputting 'pure' sinewave siren type tones rather than the current square waves. Although a downside of this could mean the output sounds softer and therefore lacks 'punch' the new circuitry compensates for this by generating a 'semi square wave' on specific tones (siren only function not speech) to re-introduce a penetrative effect that immediately grabs attention.

As a result, the improved clarity of the sound makes the output from the new technology amplifier sound louder than traditional devices, and where this improved clarity is more so for speech frequencies (variables) than siren tones (pronominally fixed).

Also, further improvements are gained as the speaker is now better matched to the amplifier output driver circuitry, that is mostly to do with driving the fundamental sine waves, rather than the harmonics from the square waves. Thus, achieving better matching that equates to better efficiency and hence better volume in that 60 Watts sounds more like 80 Watts.

Another bonus is that the higher output devices can produce a 'Low Frequency' rumble sound via a specialized speaker.

All units have a CAN Bus port for connection to other MCS devices.

Digital Sirens Class D are available:

60 Watt Rated - Utilises single 8 Ohm Siren Speaker

200 Watt Rated - The 'Ultimate Siren Solution'

Can utilise the following speaker formats/combinations:

- 1 x 200 Watt 4 Ohm Standard Tones
- 2 x 100 Watt 8 Ohm Low Frequency (Rumble) Tones
- 2 x 100 Watt 8 Ohm Same Tones (Typically both Wail or Yelp)
- 2 x 100 Watt 8 Ohm Different Tones (Typically 1 x Wail 1 x Yelp)
- 1 x 100 Watt 8 Ohm Standard Tones

Note: 1 x 200 Watt and 2 x 100 Watt Low Frequency (Rumble) speakers can be utilised on a common installation, but usually on larger vehicles (typically 4x4's or Fire Appliances due to the space required)

Electronic Siren Amplifiers

By utilising traditional analogue electronic power amplifiers that operate with step-up transformers to convert low power electronic signals into high power outputs to provide 100 Watts of audio power, these units remain the go-to siren amplifier for a basic Blue's & Two's hazard warning siren system.

These devices have not only stood the test of time both in terms of reliability and performance, but all units are packed with the features and functions now required to be the norm with traditional siren technology including:

- Horn Ring Transfer (HRT)
- Choice of a wide variety of Siren Tones
- Discreet control signal inputs for independent operation

All units have a CAN Bus port for connection to other MCS devices.

Loudspeakers

Standby RSG offers a comprehensive range of speakers however all our Siren Amplifiers are compatible with speakers from other reputable suppliers.

In general digital siren amplifiers are optimised for use with 8 Ohm impedance speakers but traditional siren amplifiers can be used with either 8 Ohm or 11 Ohm speakers. However, for our 200 Watt digital siren amplifier 4 Ohm device is required. In addition to the standard round speaker unit Standby RSG also offers a range of Extension Tubes as well as Flat Speakers.



Digital Siren Amplifiers

By utilising digital technology, Class D siren amplifiers have several advantages over traditional analogue power amplifiers that rely on transformers to convert low power electronic signals into high power outputs.

Our range of solid state digital technology amplifiers are highly efficient in converting low power signals into higher ones together with allowing waveforms to be processed and configured giving a more noticeable audio warning sound.

See pages 4:30 - 4:32 for product specifications.



Electronic Siren Amplifiers

Traditional analogue electronic power amplifiers operate with step-up transformers to convert low power electronic signals into high power outputs to provide 100 Watts of audio power, these units remain the go-to siren amplifier for a basic Blue's & Two's hazard warning system.

These devices have stood the test of time both in terms of reliability and performance and are packed with the required features and functions.

See pages 4:33 - 4:34 for product specifications.



Loudspeakers

Loudspeakers are essential to deliver the loud, clear sound required of a siren amplifier within an emergency service vehicle.

We offer a variety of loudspeakers with power ratings from a highly efficient 100W to a powerful high performance 200W. All versions are manufactured to top industry standards to help withstand the rigours of daily use with a range of sizes and designs to fit comfortably in the increasingly confined areas of vehicle engine bay.

See pages 4:35 - 4:37 for product specifications.



Complimentary Operational Devices

It is inevitable that a siren/speaker set-up may need slight adjustments or additions to fully suit a particular application.

We offer devices that can operate as stand alone intercom units and/or provide automatic pre-recorded voice announcements for vehicles with built-in segregated compartments as well as devices that reduce output while maintaining the correct impedance between a siren amplifier and speaker.

See pages 4:38 - 4:39 for product specifications.



MCS-DDSA 200W Digital Siren UNI-SIR-D20

Digital amplification technology generates a more noticeable sound both in terms of dB and audible perception. Plus has the integrated capability to produce a 'Rumble Effect' by generating penetrating/vibrating low frequency sound waves that migrate through solid objects so the siren can be physically FELT!

PRODUCT OVERVIEW

The MCS-DDSA siren incorporates multi mode functionality. Because it is based on digital technology it can operate in different modes on the same installation by utilising different sets of speakers, if required.

Pumping out 200 Watts of 'real' dB power, unlike other offerings that are rated at 200 Watts as that is how much power they consume rather than reflecting how loud they actually are. The MCS-DDSA is unlike any other amplifier currently on the market and can truly **Make Your Presence Known!**

It can produce two different siren tones at the same time giving a 'two vehicle' effect via 2 x 100 Watt speakers, or scrolled siren sounds via a 1 x 200 Watt speaker, plus, if required either 'simultaneously or separately' a low frequency rumble sound via 1 or 2 x special (rumble woofer) speakers.

With circuitry based on Class D digital siren technology this device is optimised to produce a true 200 Watt output or if preferred 2 x 100 Watt outputs with or without the optional low frequency rumble effect.

It can be controlled with conventional switches via on/off controls, in conjunction with the Horn Ring Transfer (HRT) feature if required and/or via CAN Bus signals for other complementary MCS controllers and switch units.

MCS-DDSA functions and features:

- 12 and 24 volt operation
- Interconnects to related products via proprietary CAN Bus
- Operates via a MCS Multiway Switch Unit or directly via discreet inputs
- Hands free operation via the HRT (Horn Ring Transfer) feature enables scrolling through pre-selected siren tones
- Selectable UK siren sounds with Air/Bull horn option
- Siren active output (ideal as Data Recorder Input)
- On board status LEDs
- City mode volume reduction feature
- Workshop (test) mode volume suppression

Rumble Effect Functions

- Automatic 'standard siren reduction' when Rumble effect active - typically 75%
- Automatically 'shut off' of Rumble effect to avoid accidental misuse - typically 8 seconds
- Adjustable automatic volume reduction and shut off times
- Use Rumble effect independently or with conventional sirens
- All user controlled via 'free' MCS configuration software

Absolute Maximum Ratings

- 30 volts DC supply voltage
- 20 Amps maximum

Electrical Characteristics

- Nominal supply voltage: 13.8 or 27.4 Volts DC
Typically: 168mA @ 13.8 Volts no peripherals attached
- Standby Current: System Standby
Typically: 19mA @ 13.8 Volts no peripherals attached
Maximum: 21mA
- Standby Temperature: -20°C to +70°C
- Operating temperature: -20°C to +65°C

Power

- 1 x 40 Amp DC on pluggable connector (20 Amp fuse MUST be used)
- 1 x Ground/chassis connection (40 Amp rated or more)

Digital Inputs

- 5 x positive switched inputs 1, 2 & 3, HRT + Air Horn
- 2 x negative switched (HRT & Airhorn)

Analog monitoring

- Incoming system voltage sense
- Internal temperature monitor
- Siren system current monitor

Outputs

- 3 x High or Low switching 500mA rated outputs with in-line resettable fuse
- Amplifier outputs typically into a 8 Ohm speaker load

Communication

- 1 x CAN Bus 2.0 full speed interface

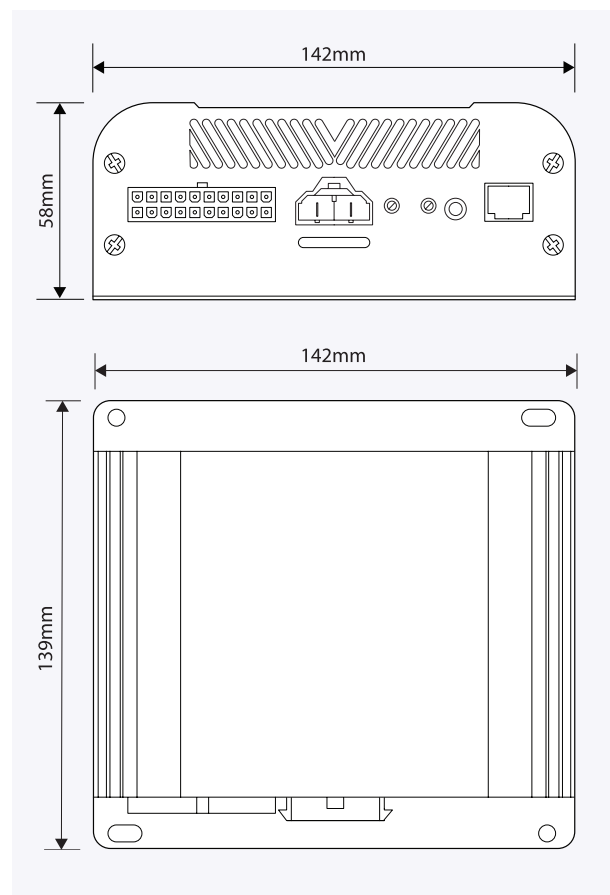

MCS-DDSA 200W DIGITAL SIREN AMPLIFIER

PART NO.	DESCRIPTION
UNI-SIR-D20	MCS-DDSA 200W Digital Siren Amplifier
45-1733	Molex Crimp Tool - Mini Fit Junior



One device, multiple applications and set-up options

At 200 Watt Rated the MCS-DDSA is the 'Ultimate Siren Solution' and can typically be set up in the following modes depending how the 2 x 100 Watt amplifier outputs are connected to various speaker options:

Can utilise the following speaker formats/combinations:

- 1 x 200 Watt 4 Ohm Standard Tones
- 2 x 100 Watt 8 Ohm Low Frequency (Rumble) Tones
- 2 x 100 Watt 8 Ohm Same Tones (Typically both Wail or Yelp)
- 2 x 100 Watt 8 Ohm Different Tones (Typically 1 x Wail 1 x Yelp)
- 1 x 100 Watt 8 Ohm Standard Tones

Note: 1 x 200 Watt and 2 x 100 Watt Low Frequency (rumble) speakers can be utilised on a common installation, but usually on larger vehicles (typically 4x4's or Fire Appliances due to the space required).

Low Frequency Rumble Tone Feature

Contributes to improving emergency vehicle operator and public safety especially in urban environments with high density heavy traffic and pedestrians. Also aids with clearing road junction passage.

When used with the 'specially matched speaker' to optimise the low frequency tones generated from the siren amplifier the output is a highly distinguishable 'Rumble' sound. As the sound is notably different to the standard siren tones that everyone is now familiar with this immediately gets peoples attention as well as a better sense of the direction the vehicle is coming from.

As the speaker is of a specialised nature, and should ideally be fitted in pairs, it is important that they are fitted correctly to take full advantage of the 'GROUND' effect. As such it is mainly appropriate to larger vehicles such as fire appliances and larger 4x4's.



Connector and Pin Kit



The Rumble Tone Effect



SET UP **OPTION 1**

Typically fire appliances or larger 4x4 vehicles

Connect to siren amplifier output 1 in parallel
Connect to siren amplifier output 2

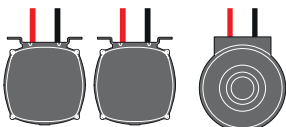

2 x digital rumble speaker: 100 Watts, 8 Ohm **LSP-108**
1 x digital speaker: 200 Watts, 4 Ohm **LSP-204**



SET UP **OPTION 2**

Typically 4x4 or larger patrol vehicles

Connect separately to outputs 1 & 2

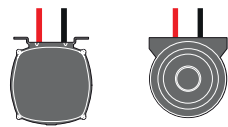

1 x digital rumble speaker: 100 Watts, 8 Ohm **LSP-108**
1 x electronic speaker: 100 Watts, 8 Ohm **LSP-210**



SET UP **OPTION 3**

Typically traffic or fast response cars

Connect to output 1



1 x digital speaker: 200 Watts, 4 Ohm **LSP-204**



SET UP **OPTION 4**

Typically any suitable vehicle

Connect separately to outputs 1 & 2

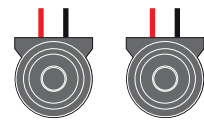

2 x electronic speakers: 100 Watts, 8 Ohm **LSP-210**

MCS-DSA 60W Digital Siren

Digital amplification technology generates a more noticeable sound both in terms of dB output and audible perception

PRODUCT OVERVIEW

The 60 Watt Digital Siren can operate either in conjunction with other MCS devices via the on-board CAN Bus interface or as an independent standalone compact device with optional input and output control lines.

MCS-DSA60 functions and features:

- 12v operation
- Interconnects to related products via proprietary CAN Bus
- Operates via a MCS Multiway Switch Unit or directly via discreet inputs
- Hands free operation via the HRT (Horn Ring Transfer) feature enables scrolling through pre-selected siren tones
- Selectable UK siren sounds with Air/Bull horn option
- Siren active output (ideal as Data Recorder Input)
- On board status LEDs
- City mode volume reduction feature
- Workshop (test) mode volume suppression

Speaker Requirements

- MCS-DSA60 - 4 Ohm, 60 Watt or 100 Watt rated
- See page 4:37 for speaker options

Absolute Maximum Ratings

- 18 volts DC supply voltage
- 10 Amps maximum

Electrical Characteristics

- Nominal supply voltage: 13.8 Volts DC
Typically: 168mA @ 13.8 Volts no peripherals attached
- Standby Current: System Standby
Typically: 19mA @ 13.8 Volts no peripherals attached
Maximum: 21mA
- Standby Temperature: -20°C to +70°C
- Operating temperature: -20°C to +65°C

Power

- 1 x 20 Amp DC on pluggable connector (10 Amp fuse MUST be used)
- 1 x Ground/chassis connection (20 Amp rated or more)

Digital Inputs

- 5 x positive switched inputs 1, 2 & 3, HRT + Air Horn
- 2 x negative switched (HRT & Airhorn)

Analog monitoring

- Incoming system voltage sense
- Internal temperature monitor
- Siren system current monitor

Outputs

- 3 x High or Low switching 500mA rated outputs with in-line resettable fuse
- 60W rated amplifier outputs into suitable 4 Ohm speaker load

Communication

- 1 x CAN Bus 2.0 full speed interface

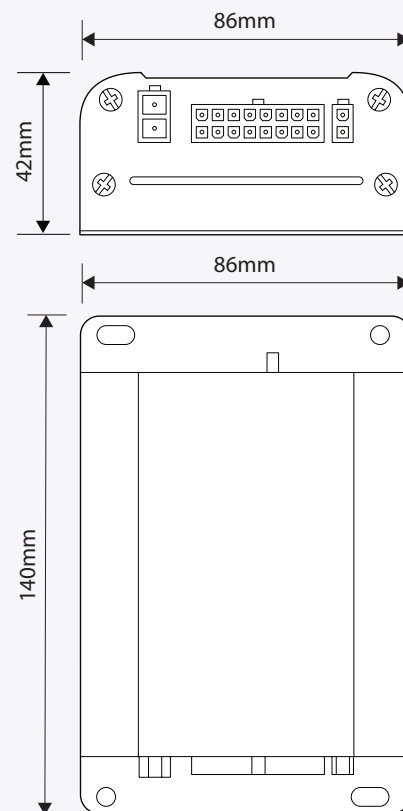

MCS-DSA 60 WATT DIGITAL SIREN

PART NO.	DESCRIPTION
UNI-SIR-D60	MCS-DSA 60 CAN D-Class Siren Amp
UNI-SIR-D62	MCS-DSA 60 UK2 D-Class Siren Amp, W-Y
UNI-SIR-D63	MCS-DSA 60 UK3 D-Class Siren Amp, W-Y-2T
UNI-SIR-D64	MCS-DSA 60 UK4 D-Class Siren Amp, W-Y-2T-P
45-1733	Molex Crimp Tool - Mini Fit Junior

Key: W = Wail, Y = Yelp, 2T = Two Tone, P = Phasor

MCS-SE Universal 100W Siren

Our comprehensive stand-alone device that can operate as a PA and Radio re-broadcast function. It also has a selection of digital control inputs, switching outputs and analogue monitoring.

PRODUCT OVERVIEW

Use as a stand-alone device or as part of a blue's and two's system. A compact 100W siren unit which operates at both 12v and 24v and also includes a PA facility.

MCS-SE functions and features:

- 12v and 24v operation
- Interconnects to related products via proprietary CAN Bus
- Can be enabled from an input or compatible multi-way switch
- Hands free operation via the HRT (Horn Ring Transfer) feature enables scrolling through pre-selected siren tones
- Selectable UK and European siren sounds with Air/Bull horn option
- Siren active output (ideal as Data Recorder Input)
- PA & radio re-broadcast facility
- Supports 8 and 11 Ohm speakers
- City mode volume reduction feature
- Workshop mode volume suppression feature for testing

The MCS-SE can also be linked with the following compatible devices to create a 'two siren' sound effect from one vehicle:

- MCS-32 Universal Controller Plus UNI-PLS-001
- MCS-SE Universal 100 Watt Siren UNI-SIR-001
- MCS-SSA Basic Stand-alone Siren PAA-167-03

Resulting in the following system functions and features:

- Tones from each unit will be different
- Tones from each device will be un-synchronised to give a two vehicle effect
- Dual 100 Watt Siren outputs via two separate 100 Watt speakers

Absolute Maximum Ratings

- 34 volts DC supply voltage
- 15 Amps maximum
- 4 milliamps typical standby current - switch de-activated
- 22 milliamps typical standby current - switch activated
- 35 milliamps maximum standby current - switch activated
- -20°C to +70°C standby temperature
- -20°C to +65°C operating temperature

Power

- 1 x DC on pluggable adaptor (15 Amp fuse must be used)
- 1 x Ground/chassis connection (should be rated to handle 15 Amps or more)



Digital Inputs

- 3 x positive/negative switched
- 2 x positive switched (HRT, Airhorn)
- 2 x negative switched (HRT, Airhorn)

Analog monitoring

- Incoming system voltage sense
- Internal temperature monitor
- Siren system current monitor
- System has cooling using internal fan

Outputs

- 3 x high or low switching 500 milliamps rated transistors with internal re-settable fuse protection
- 100w siren speaker output 8 or 11 Ohm selectable

Communication

- 1 x CAN Bus 2.0 full speed interface

UNIQUE FEATURE

YELP & WAIL AT THE SAME TIME!

Connect two compatible units together via CAN port for un-synchronised output of two different siren sounds at the same time simulating multiple vehicles from one car.

MCS-SE UNIVERSAL 100W SIREN	
PART NO.	DESCRIPTION
UNI-SIR-001	MCS-SE 100W Siren Amplifier
45-1733	Molex Crimp Tool - Mini Fit Junior

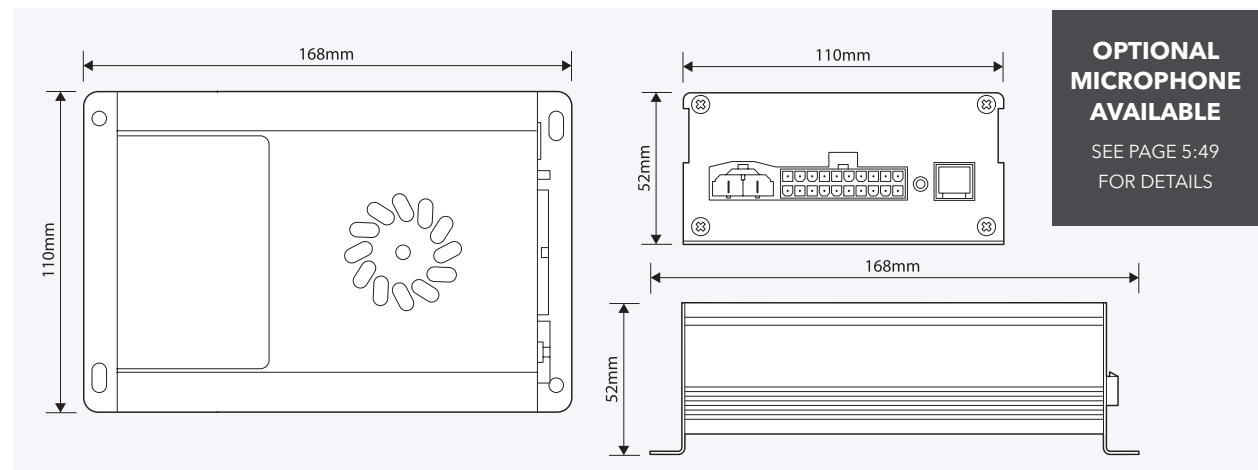

MCS-SSA Basic 100W Siren Amplifier

Our most basic stand-alone device that operates just as a siren, with various options depending on the required siren sound. It also has digital control inputs to select all standard siren functions

PRODUCT OVERVIEW

Use as an economic stand-alone device or as part of a blue's and two's system. A compact 100W siren unit which operates at both 12v and 24v.

MCS-SSA functions and features:

- 12v and 24v operation
- Interconnects to related products via proprietary CAN Bus
- Can be enabled from an input or compatible multi-way switch
- Hands free operation via the HRT (Horn Ring Transfer) feature enables scrolling through pre-selected siren tones
- Selectable UK siren sounds with Air/Bull horn option
- Siren active output (ideal as Data Recorder Input)
- On board status LEDs
- Supports 8 and 11 Ohm speakers
- City mode volume reduction feature
- Workshop mode volume suppression feature for testing

The MCS-SSA can also be linked with other compatible siren devices to create a 'two siren' sound effect from one vehicle when used with one of the following devices:

- MCS-32 Universal Controller Plus UNI-PLS-001
- MCS-SE Universal 100 Watt Siren UNI-SIR-001

With the following system functions and features:

- Tones from each unit will be different
- Tones from each device will be un-synchronised to give a two vehicle effect
- Dual 100 Watt Siren outputs via two separate 100 Watt speakers

Absolute Maximum Ratings

- 34 volts DC supply voltage
- 15 Amps maximum
- 4 milliamps typical standby current - switch de-activated
- 22 milliamps typical standby current - switch activated
- 35 milliamps maximum standby current - switch activated
- -20°C to +70°C standby temperature
- -20°C to +65°C operating temperature

Power

- 1 x DC on pluggable adaptor (15 Amp fuse must be used)
- 1 x Ground/chassis connection (should be rated to handle 15 Amps or more)

Digital Inputs

- 1 x positive/negative switched
- 1 x positive switched (HRT, Airhorn)
- 1 x negative switched (HRT, Airhorn)

Analog monitoring

- Incoming system voltage sense
- Internal temperature monitor
- Siren system current monitor

Outputs

- 100W siren speaker output 8 or 11 Ohm selectable

Communication

- 1 x CAN Bus 2.0 full speed interface

UNIQUE FEATURE YELP & WAIL AT THE SAME TIME!

Connect two compatible units together via CAN port for un-synchronised output of two different siren sounds at the same time simulating multiple vehicles from one car.

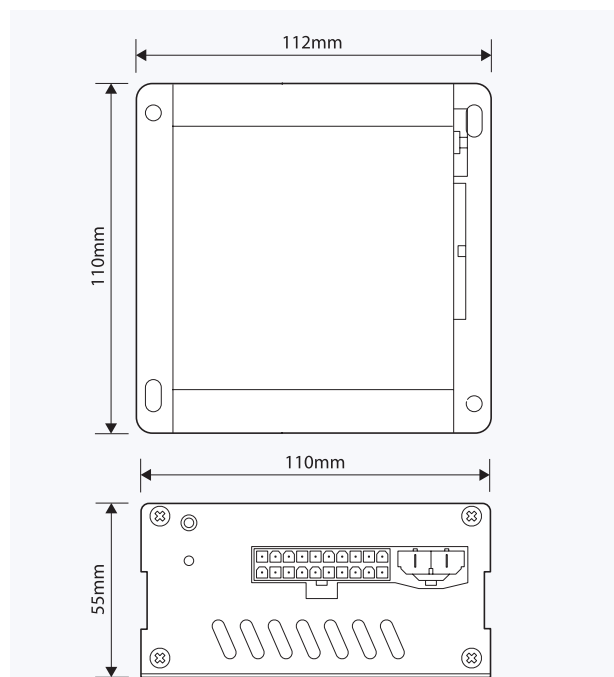

MCS-SSA BASIC 100W SIREN AMPLIFIER

PART NO.	DESCRIPTION
PAA-167-03	Basic 100W Siren Amplifier - Cycle Wail/Yelp Press and Hold Air Horn - No PA
PAA-172-03	Basic 100W Siren Amplifier - Cycle Wail/Yelp Independent Air Horn (separate switch) - No PA
PAA-173-03	Basic 100W Siren Amplifier - Cycle Wail/Yelp/Two Tone Press and Hold Air Horn - No PA
PAA-174-03	Basic 100W Siren Amplifier - Cycle Wail/Yelp/Two Tone/Phasor Press and Hold Air Horn - No PA
PAA-175-03	Basic 100W Siren Amplifier - Cycle Wail/Yelp/Off Press and Hold Air Horn - No PA
45-1733	Molex Crimp Tool - Mini Fit Junior

Siren Speaker Options

60W Round Speaker 11-1031

Our most compact speaker ideal for tight spaces and where 100 Watt output is too high. Designed to operate with a 60 Watt siren and PA amplifier.

- 60W output power rating
- 4 Ohms impedance
- Only suitable for 60 Watt siren and/or PA operation
- Strong cast metal housing and formed metal cowl
- Heavy duty metal mounting bracket
- Powder coated to prevent rusting
- See page 4:37 for dB levels rating chart

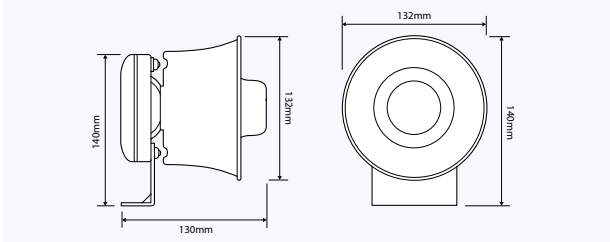

100W Round Speaker LSP-210

Our most popular and economical speaker designed to work in conjunction with a 100 Watt siren amplifier.

- 100W output power rating
- 8 Ohms impedance
- Suitable for 60 and 100 Watt siren and/or PA operation
- Strong cast metal housing and formed metal cowl
- Heavy duty metal mounting bracket
- Powder coated to prevent rusting
- See page 4:37 for dB levels rating chart

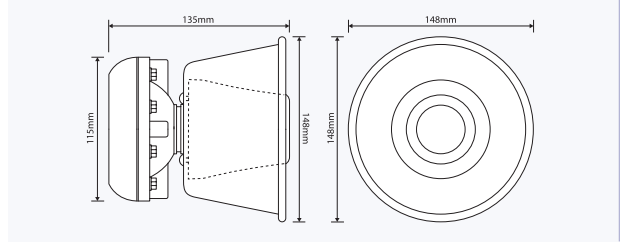

200W Round Speaker LSP-204

Our most powerful speaker designed to operate in conjunction with a 200 Watt siren and PA amplifier.

- 200W output power rating
- 4 Ohms impedance
- Suitable for 200 Watt siren and/or PA operation
- Strong cast metal housing and formed metal cowl
- Heavy duty metal mounting bracket
- Powder coated to prevent rusting
- See page 4:37 for dB levels rating chart

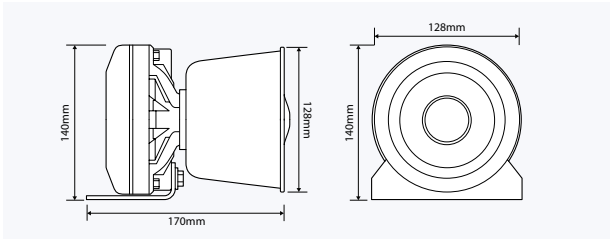

100W Flat Speaker LSP-132

A robust corrosion resistant 100 Watt flat speaker. The low profile housing makes it easy to install either horizontally or vertically behind a vehicle grille or bumper.

- 100W output power rating
- 11 Ohms impedance
- Suitable for 60 and 100 Watt siren and/or PA operation
- Strong cast metal housing
- Heavy duty metal mounting bracket
- See page 4:37 for dB levels rating chart

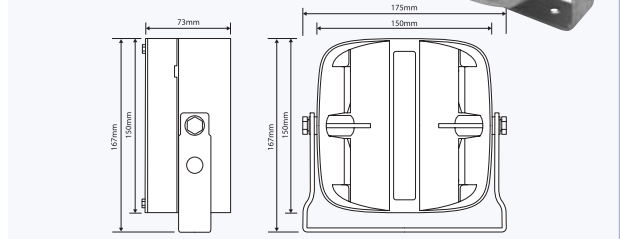
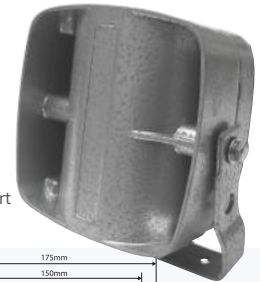

100W SlimLine Flat Speaker LSP-100

A 100 Watt SlimLine flat speaker optimised for use with digital sirens and PA. The low profile housing makes it easy to install either horizontally or vertically behind a vehicle grille or bumper.

- Optimised for use with digital sirens
- 100W output power rating
- 8 Ohms impedance
- Suitable for 60 and 100 Watt siren and/or PA operation
- Strong cast and machined metal housing
- Heavy duty metal mounting bracket
- Painted finish to prevent rusting
- See page 4:37 for dB levels rating chart

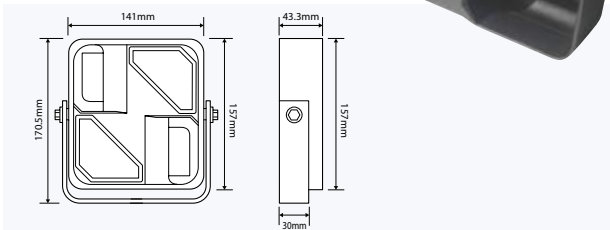
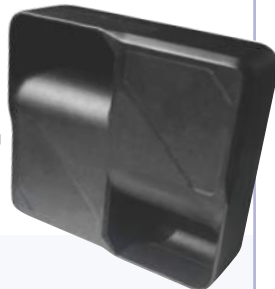

Speaker Reduction Transformer ACC-308

For use with electronic sirens only as digital sirens have an inherent volume control. This simple passive device reduces the siren output from a 100 Watt siren down to 60 Watts.

- Balanced transformer maintains correct impedance between electronic siren amplifier and 100 Watt rated speaker, like our LSP-210 100 Watt round speaker
- Ideal to mount inside lightbars with integral siren speakers
- Assists in meeting Health and Safety requirements within vehicles for roof mounted siren speakers
- Ideal for testing sirens and speakers on the bench
- Fully encapsulated weatherproof housing
- Operates with both 12 and 24 volt siren amplifiers

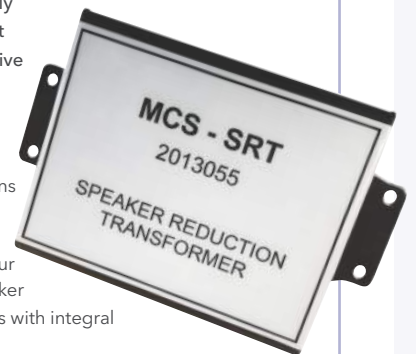

Overall dimensions: 93mm (w) x 78mm (d) x 26mm (h)

Flexi-tube Siren Pipe Extension Kit

The Flexi-tube Speaker extension consists of a tubular, moulded plastic sound pipe that directs the sound to the front of the vehicle without compromising the quality or pitch of the siren tones.

It directly replaces the speaker cowl of our LSP-210 and LSP-204 speakers as well as other standard round speakers.

Supplied complete with 1 metre of flexible hose that can be trimmed to an alternative length if required and all necessary clamps for easy installation. Extra hose can be procured separately if required.

Tip: Occasionally moisture can collect where the hose dips, we recommend drilling a small drain hole (approx. 6mm) so water does not accumulate.

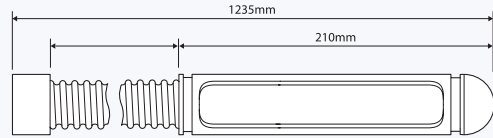

FLEXI-TUBE SIREN PIPE EXTENSION KIT

PART NO.	DESCRIPTION
11-1023	Flexi-tube Speaker Extension - 1m Hose
11-1007	Extra Hose - 10 metres

Flexi-tube Siren Pipe Extension and Speaker Kit

The Flexi-tube Siren Pipe Extension and Speaker Kit is the ideal alternative to a traditional 100 and 200 Watt siren speakers when space is at a premium.

The tubular, moulded plastic sound pipe directs the sound to the front of the vehicle without compromising the quality or pitch of the siren tones.

Supplied complete with either a 100 Watt or 200 Watt speaker driver, 1 metre of flexible hose that can be trimmed to an alternative length if required and all necessary clamps for easy installation. Extra hose can be procured separately if required.

Tip: Occasionally moisture can collect where the hose dips, we recommend drilling a small drain hole (approx. 6mm) so water does not accumulate.

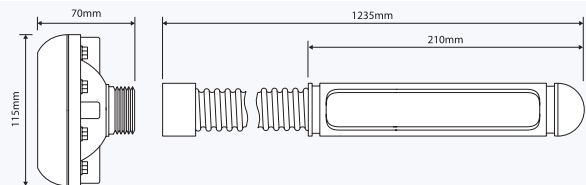

FLEXI-TUBE SIREN PIPE EXTENSION KIT

PART NO.	DESCRIPTION
KIT-132	Flexi-tube Speaker Extension + 100W Speaker Driver - 1m Hose
KIT-100	Flexi-tube Speaker Extension + 200W Speaker Driver - 1m Hose
11-1007	Extra Hose - 10 metres

100 Watt Low Frequency (Woofers) Speaker LSP-108

Designed to take full advantage of the low frequency rumble tone function available from our 200 Watt Class D Digital Siren by utilising the 'Ground Effect', where low frequency sound waves penetrate through solid object so they can be physically FELT!

As usually fitted in conjunction with conventional speakers can be used either independently for the rumble effect or simultaneously with other siren tones.

- 100W output power rating
- 8 Ohms impedance
- Suitable for 100 Watt low frequency operation only
- Heavy duty construction and metal mounting bracket
- See page 4:37 for dB levels rating chart

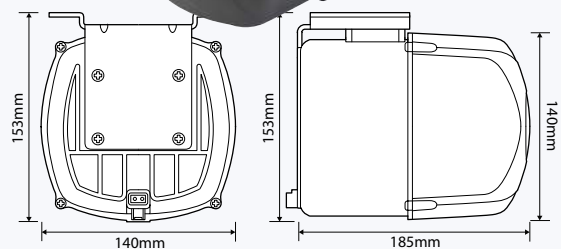

MCS-AIC Audio Intercom Controller UNI-AIC-001

Connect to a MCS Control Unit to add voice information warning messages as well as an intercom facility

PRODUCT OVERVIEW

A compact audio control unit that can provide automatic announcements and pre-recorded verbal messages and/or provide intercom facilities between persons in vehicles with separate front and rear compartments such as Box Ambulances and Prison Vans. Where the unit can be used either as a stand-alone device or in conjunction with our range of MCS Control Units to provide more interactive control with other vehicle functions. As such the device can be set-up in three different modes of operation:

- Pre-recorded Message Announcement in conjunction with MCS control units
- Stand-alone Audio Intercom Controller Kit
- Pre-Recorded Message Announcement and Audio Intercom Controller Kit in conjunction with MCS control units

Pre-Recorded Message Announcement Mode:

When the Audio Intercom Controller device is set-up in this mode either single or multiple pre-recorded messages, stored on a micro SD memory card (not supplied), can be broadcast through the unit when controlled by a MCS control unit. To allow total flexibility with the message content, that are normally verbal announcements with or without sound effects, they are first recorded using the Windows Wave application on a PC and then downloaded on to a SD memory card that is then inserted into the AIC.

Audio Intercom Controller Mode:

When the AIC device is set-up in this mode (either with or without a MCS control unit) it can be used as either a Simplex (1-Way) or Duplex (2-Way) Intercom system, depending upon the desired operating method for particular types of vehicles and their associated operational practises. Where for example 'speaking priority' can be allocated to either the front or rear operator depending whether the Push to Talk (PTT) switch is either latching or momentary in action. Also when used in conjunction with a MCS control unit the Intercom facility can have the PTT function associated with a Multi-Way Switch button, as well as being linked-in with other vehicle operations such as when the blue's & two's are active.

Combined Pre-Recorded Message Announcement and Audio Intercom Controller Mode:

When the AIC is set-up in this mode it acts as a device that both Announces Pre-Recorded Messages as well as acting as an Intercom. However, due to the potential complexity of this application this mode can only be applied when used in conjunction with our MCS-32 device.

General Features and Functions

The unit is designed so it may be discreetly mounted behind a panel with microphones and speakers positioned in convenient and accessible locations.

- Clear voice communication between front and rear vehicle compartments
- Messages stored on Micro SD card (not supplied)
- Can broadcast pre-recorded messages
- Optional ignition sense input to switch on and off via ignition
- Compact size
- Built-in heat sink for constant operation
- 2 x active microphone and control switches are supplied separately so can match operational requirements and vehicle interior aesthetics
- Standard speakers, microphones and PTT switches are available from Standby RSG if required
- If required PTT switches can be buttons associated with Multi-Way Switch units

AUDIO INTERCOM CONTROLLER COMPONENTS

PART NO.	DESCRIPTION
UNI-AIC-001	MCS-AIC Audio Intercom Controller Unit
UNI-PRO-002	Universal MCS Software CD
UNI-MIC-007	Panel Mount Microphone
16-1093	Latching PTT Switch
16-1431	Momentary PTT Switch
PCH-102-18	32GB Micro SD HC Class 10 Memory Card

Audio Accessories

Various Loudspeakers Available

Contact our sales team to discuss requirements.

Panel Mount Microphone UNI-MIC-007

Dynamic microphone pre-wired to 3.5mm stereo jack plug with pre amp. Suitable for standard panel mounting.

Latching PTT Switch 16-1093

Round latching switch with LED 'ON' indicator.

Momentary PTT Switch 16-1431

Round momentary switch with LED 'ON' indicator.



TYPICAL VOICE ANNOUNCEMENT MESSAGES FOR SPECIFIC APPLICATIONS

PUBLIC TRANSPORT	MEDICAL PATIENT TRANSPORT	REFUSE COLLECTION
• BEWARE DOORS CLOSING	• BEWARE RAMP DEPLOYING	• BEWARE BIN TIPPING
• DOORS OPENING - LIGHT VEHICLE	• BEWARE RAMP RETRACTING	• BEWARE BIN LOWERING
• DOORS OPENING - ENTER VEHICLE	• HOLD TIGHT VEHICLE ABOUT TO MOVE	• WARNING VEHICLE REVERSING
• CAUTION RAMP DEPLOYING	• HOLD TIGHT VEHICLE STOPPING	• WHITE NOISE 'REVERSING'
• CAUTION RAMP RETRACTING	• MEDICAL STORE OPEN	• WARNING VEHICLE MANOEUVRING
• HOLD TIGHT VEHICLE ABOUT TO MOVE	• MEDICAL SAFE OPEN	• WARNING VEHICLE TURNING RIGHT
• HOLD TIGHT VEHICLE STOPPING	• WARNING VEHICLE REVERSING	• WARNING VEHICLE TURNING LEFT
• KINDLY HAVE CORRECT FARE OR CARD READY	• WHITE NOISE 'REVERSING'	• CAUTION VEHICLE COMPACTING



Typical Application Schematic

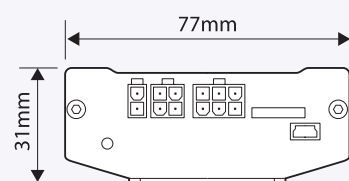
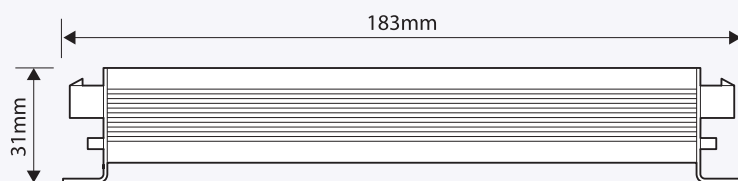
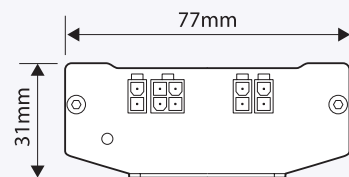
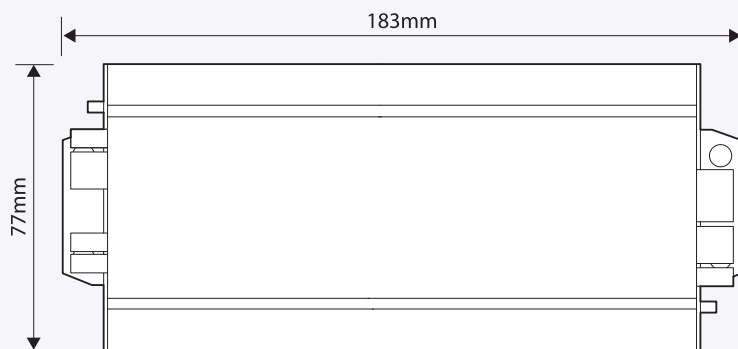
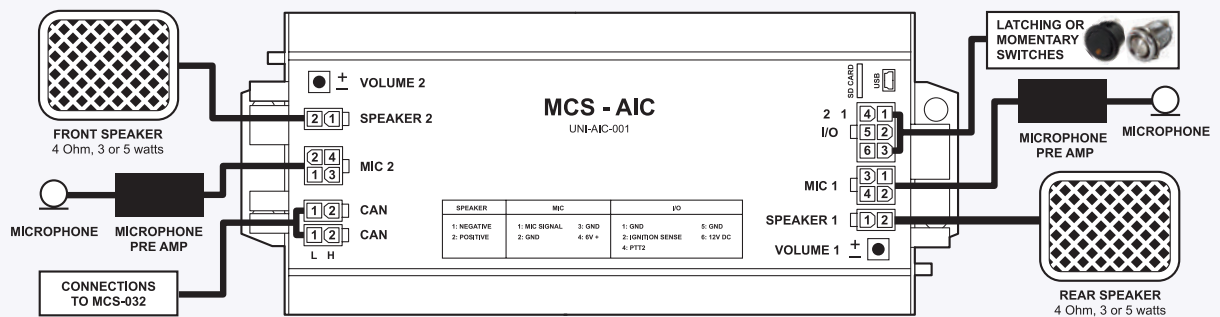

See page 7:65 for typical system specifications

Section 5 :

MCS Switch Units & Panels

An extremely versatile range of fully programmable switch units and panels with user defined legends to suit a variety of applications.

We have a variety of switch units and panels which include a range of handsets with a minimum of 5 up to a maximum 16 individual buttons including a built-in microphone and push to talk (PTT) if required. We also have a selection of surface/flush mounted units for installation within the vehicle console area, these are available with a minimum of 5 and a maximum of 16 buttons where audio output would be achieved via a hand held microphone with a PTT switch. We now also have a comprehensive range of switch panels with a cast aluminium surround for a robust installation option.

In addition to the standard switch/panel options we now have a touch screen control panel with backlit LCD display.

Each switch can be independently configured in terms of operation, legend designation and even back light colour, therefore they are the ideal interface for operating the MCS range of control units.

Main Features

- An extensive range of slimline switch units
- Meet automotive protrusion regulations
- Fully programmable at source and/or by customer
- Each switch can have a multi-function 'HOT' key action depending on required function
- Handset versions have a built-in microphone. Any switch can then be programmed to act as PTT (Push To Talk) when used in conjunction with Public Address (PA) equipment
- DIN/Flush mount units require a separate microphone
- Adjacent buttons can be combined for extra visual impact (where practical)
- Interactive buttons for interactive lighting functions and audio warnings - one button turns others on or off
- 3 stage back illumination - low brightness when OFF, high brightness when ON and both levels dimmed at night
- Back light colour can be set to suit switch function
- Multiple mounting options for each type of switch unit

Each button can operate independently or in conjunction with other buttons, as well as having unique legends, therefore each device would need to be uniquely configured. A configuration specification sheet is available which allows you to initially define the solution required along with the associated switch unit which will depend upon the level of control necessary. Once programmed customers can then implement further audio and visual applications via the MCS control system it is linked with.



RSC Engineering Limited
 16 Button DIM/Flush Mount (UK MP 3162-PT16)

Universal Multi-Way Switch Unit Specification Sheet

Button No.	Legend (up from Source)	Colour	S	M
1				
2				
3				
4				
5				
6				
7				
8				
9				
10				
11				
12				
13				
14				
15				
16				

Customer: _____ Date: _____

Hand Held Switch Units

A range of multi-functional hand held switch units that interface with MCS control units for the operation of vehicle hazard warning systems.

A range of handsets with a minimum of 5 up to a maximum 16 individual buttons including a built-in microphone and push to talk (PTT) if required.

Each switch can be independently configured in terms of operation, legend designation and back light colour.

See page 5:44 - 5:46 for product specifications.



Surface/flush Mount Switch Units

A range of multi-functional surface/flush fit switch units that interface with MCS control units for the operation of vehicle hazard warning systems.

A selection of surface/flush mounted units for installation within the vehicle console area, these are available with 5 to 16 buttons.

Each switch can be independently configured in terms of operation, legend designation and even light colour.

See page 5:47 - 5:48 for product specifications.



Custom Made Switch Units

Switch units can be custom designed to fit a specific area of the vehicle and interface with MCS control units for the operation of vehicle hazard warning systems.

Switches are based on standard switch unit configurations with a custom made housing and fascia to fit within a specific area.

Each switch can be independently configured in terms of operation, legend designation and back light colour.

See page 5:49 for product specifications.



Switch Panels

A new range of multi-functional switch panels that interface with MCS control units for the operation of vehicle hazard warning systems.

An aluminium surround that insets into the body work and is secured from the front to allow for easy removal/replacement makes these panels ideal for situations that require a more robust switching solution.

Each switch can be independently configured in terms of operation, legend designation and light colour.

See page 5:50 - 5:51 for product specifications.



Touch Screen Controller

The MCS-TSC operates hazard warning equipment through a clear, intuitive touch screen display with direct access keys for primary functions.

The rubberised casing provides a tactile, robust, military style switch unit.

See page 5:52 - 5:53 for product specifications.



MCS Switch Units & Panels Guide

The current standard range of MCS switch units and panels

Hand held switch units

8 button
(8 small)



7 button
(6 small, 1 double)



T8 Mini Handset
UNI-MIN-XXX

- 8 or 7 buttons
- The 2 bottom buttons join together to make one button that can have dual functions making a 7-way unit
- Supplied with rubber surround and dashboard clip
- Can be dash mounted via M4 inserts on reverse or inset into dash via custom made aperture
- Optional PTT
- 111mm x 56mm x 19mm including rubber surround

Option 1: 8-way (8 small)
Option 2: 7-way (6 small and 1 double)



10 button
(10 small)



9 button
(8 small, 1 double)



8 button
(6 small, 2 double)



T10 Midi Handset
UNI-MID-XXX

- 10, 9 or 8 buttons
- The 2 bottom buttons join together to make one button that can have dual functions making a 9-way unit, the 4 bottom buttons join together to make two double buttons that can have dual functions making an 8-way unit
- Supplied with rubber surround and dashboard clip
- Can be dash mounted via M4 inserts on reverse or inset into dash via custom made aperture and optional quick fit rubber boot
- Optional PTT
- 146.5mm x 56mm x 19mm including rubber surround

Option 1: 10-way (10 small)
Option 2: 9-way (8 small and 1 double)
Option 3: 8-way (6 small and 2 double)

16 button
(16 small)



15 button
(14 small, 1 double)



14 button
(12 small, 2 double)



T16 MaxiPlus Handset
UNI-MXH-XXX

- 16, 15 or 14 buttons
- The 2 bottom buttons join together to make one button that can have dual functions making a 15-way unit, the 4 bottom buttons join together to make two double buttons that can have dual functions making a 14-way unit
- Supplied with rubber surround and dashboard clip
- Can be dash mounted via M4 inserts on reverse or inset into dash via custom made aperture
- Optional PTT
- 156mm x 56mm x 19mm including rubber surround

Option 1: 16-way (16 small)
Option 1: 15-way (14 small and 1 double)
Option 1: 14-way (12 small and 2 double)

16 button



T17 Handset Plus
UNI-HAP-XXX

- 16 buttons
- 12 small buttons and 4 slightly larger buttons
- Handset only, supplied with rubber surround and dashboard clip
- Optional PTT via an externally operated grab switch
- 162mm x 71mm x 19.5mm including rubber surround, not including PTT switch

Option 1: 16-way (12 small and 4 large)

16 button



T17 Display Handset Plus
UNI-DIS-XXX

- 16 buttons + LCD Display
- 12 small buttons, 4 slightly larger buttons and backlight LCD display
- Handset only, supplied with rubber surround and dashboard clip
- Optional PTT via an externally operated grab switch
- 162mm x 71mm x 19.5mm including rubber surround, not including PTT switch

Option 1: 16-way (12 small, 4 large + LCD display)

Combining buttons

These pages show the current standard range of MCS Handsets and Switch Units.

In most cases it is possible to combine 2 small buttons that are side by side when horizontal or above and below each other when vertical thereby creating one large (double) button with dual functionality as well as increased visual impact.

Combining buttons will require engineering input which will in turn mean a longer lead time than a standard unit.

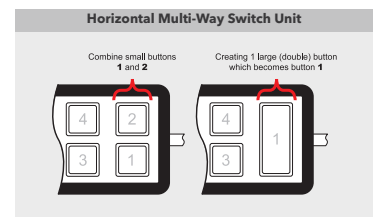
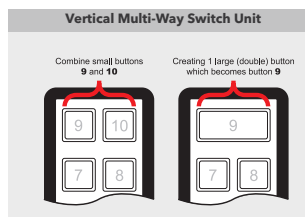

Examples of combining 2 small buttons to create 1 double button, buttons must be adjacent to each other.
Note: Slimline and Maxi units have alternative designs which include large buttons, these are not 2 buttons combined furthermore they cannot be combined to make one button.

Flush/DIN mounted switch units

5 button

(4 small, 1 large)



F5 Slimline Switch Unit

UNI-SLM-XXX

- 5 small buttons or 4 small buttons and 1 large button

The large button on this option is NOT 2 buttons combined this is simply an alternative design

- Flush fit only, no rubber surround
- No PTT
- 124mm x 32mm x 14.6mm

Option 1: 5-way (5 small buttons)

Option 2: 5-way (4 small and 1 large button)

5 button

(5 small)



10 button

(8 small, 2 large)



F5D Slimline Switch Unit

UNI-SLD-XXX

- 8 small buttons and 2 large buttons
- The large buttons on this option are NOT 2 buttons combined this is simply an alternative design

- Flush fit only, no rubber surround
- No PTT
- 248mm x 32mm x 14.6mm

Option 1: 10-way (8 small buttons and 2 large buttons)

F5T Slimline Switch Unit

UNI-SLT-XXX

15 button

(13 small, 2 large)



- 13 small buttons and 2 large buttons
- The large buttons on this option are NOT 2 buttons combined this is simply an alternative design

- Flush fit only, no rubber surround
- No PTT
- 385mm x 32mm x 14.6mm

Option 1: 15-way (13 small buttons and 2 large buttons)

14 button

(14 small)



14 button

(12 small, 2 large)



13 button

(12 Small, 1 double)



F14 Maxi Switch Unit

UNI-MAX-XXX

- 3 options available
- 2 with 14 buttons and 1 with 13 button.

- Option 1 - 14 buttons - small buttons
- Option 2 - 14 buttons - 12 small buttons and 2 large buttons. The large buttons on this option are NOT 2 buttons combined this is simply an alternative design

- Option 3 - 13 buttons - 12 small buttons plus the 1st 2 buttons join together to make one button that can have dual functions making a 13-way unit.

- DIN mount or Flush fit only, no rubber surround.

- No PTT
- 176mm x 46mm x 14.6mm

Option 1: 14-way (14 small)

Option 2: 14-way (12 small and 2 large)

Option 3: 13-way (12 small and 1 double)

16 button

(16 small)



15 button

(14 small, 1 double)



F16 MaxiPlus DIN/Flush Switch Unit

UNI-MXF-XXX

- 16 or 15 buttons

The 2 bottom buttons join together to make one button that can have dual functions making a 15-way unit.

- DIN mount or Flush fit only, no rubber surround.

- No PTT
- 176mm x 46mm x 14.6mm

Option 1: 16-way (16 small)

Option 2: 15-way (14 small and 1 double)

20 button

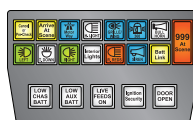

F21 Mega20 Switch Unit

UNI-MUL-XXX

- 20 buttons
- 14 small buttons, 1 double button and 5 large buttons

- Flush fit in custom aperture only, no rubber surround

- No PTT
- 150mm x 84mm x 14.6mm

Option 1: 20-way (14 small, 1 double and large)

Switch panels

8 button



T8A Mini Switch Panel

UNI-MIN-XXX

- 8 buttons
- Inset into vehicle dash or panelling
- No PTT
- 120mm x 68mm x 15mm

Option 1: 8-way (8 small buttons)

12 button



P12 MidiPlus Switch Panel

UNI-MDP-XXX

- 12 buttons
- Inset into vehicle dash or panelling
- No PTT
- 204mm x 73mm x 17mm

Option 1: 12-way (12 small buttons)

16 button



T16A MaxiPlus Switch Panel

UNI-MXP-XXX

- 16 buttons
- Inset into vehicle dash or panelling
- No PTT
- 160mm x 68mm x 15mm

Option 1: 16-way (16 small buttons)

16 button



P16 MaxiPlus Switch Panel

UNI-MXP-XXX

- 12 buttons
- Inset into vehicle dash or panelling
- No PTT
- 255mm x 73mm x 17mm

Option 1: 16-way (16 small buttons)

T8 Mini Switch Unit UNI-MIN-XXX

Available as an 7-Way or 8-way switch unit as standard, can also be configured to have between 4, 5 and 6 buttons if required.

Our standard T8 Mini Switch Unit configuration consists of 8 small buttons or 7 buttons (six small and one double) with the appropriate legend and key colour, however, by combining 2 small buttons to make 1 large button the unit can have as few as 4 buttons if required.

Additionally any button can be programmed for use as PTT (Push To Talk) when activating the built-in microphone.

Small in size, this unit can be mounted in a variety of ways for both overt and covert applications. This flexibility is achieved as the reverse of the handset has M4 threaded inserts for the addition of a microphone type clip and bracket or to facilitate permanent mounting.

A removable, rubber surround encases the unit resulting in a robust, hard wearing, professional switch solution.

- 8 or 7 buttons, the bottom two buttons join together to make one button that can have dual functions making a 7-Way switch unit
- Small buttons can have dual function increasing versatility
- Button colours are defined by the LED back light, therefore they have no colour when the handset is 'Off'
- Optional programmable PTT (push-to-talk)
- All configurations compatible with the full range of MCS Control Units

Overall dimensions: 111mm (h) x 56mm (w) x 19mm (d)

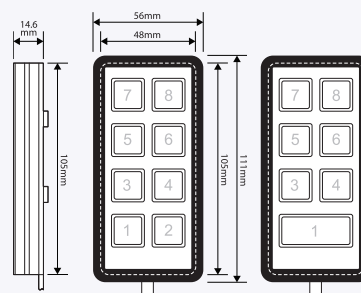

T10 Midi Switch Unit UNI-MID-XXX

Available as an 8-Way, 9-Way or 10-way switch unit as standard, can also be configured to have 5, 6 and 7 buttons if required.

Our standard T10 Midi Switch Unit configuration consists of 10 small buttons, 9 buttons (8 small and one double) or 8 buttons (6 small and 2 double) with the appropriate legend and key colour, however, by combining 2 small buttons to make 1 large button the unit can have as few as 5 buttons if required.

Additionally any button can be programmed for use as PTT (Push To Talk) when activating the built-in microphone.

Small in size, this unit can be mounted in a variety of ways for both overt and covert applications. This flexibility is achieved as the reverse of the handset has M4 threaded inserts for the addition of a microphone type clip and bracket or to facilitate permanent mounting.

A removable, rubber surround encases the unit resulting in a robust, hard wearing, professional switch solution.

This switch unit is also available with an optional quick fit rubber shroud (ACC-316) which allows the unit to be inset.

- 8, 9 or 10 buttons, the bottom two buttons join together to make one button that can have dual functions
- Small buttons can have dual function increasing versatility
- Button colours are defined by the LED back light, therefore they have no colour when the handset is 'Off'
- Optional programmable PTT (push-to-talk)
- All configurations compatible with the full range of MCS Control Units

Overall dimensions: 146.5mm (h) x 56mm (w) x 19mm (d)

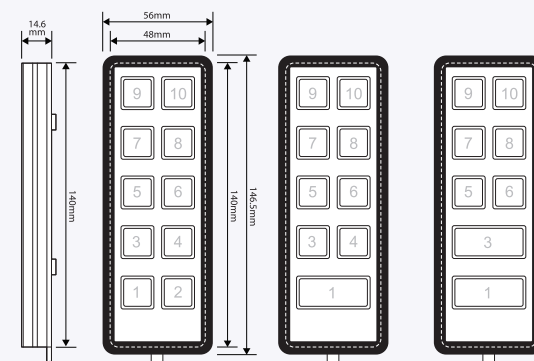
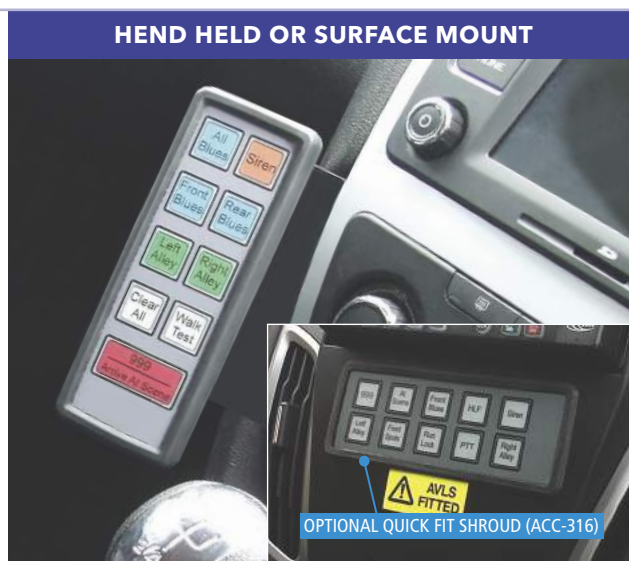

T16 MaxiPlus Switch Unit UNI-MXH-XXX

Available as an 14-Way, 15-Way and 16-way switch unit as standard, can also be configured to have between 8 and 13 buttons if required.

Our new T16 Switch Unit has the same button configurations as its previous incarnation however the introduction of a rigid plastic fascia grid that is secured with 2 small screws vastly improves button definition as well as making it easy for the user to replace/update legends.

Additionally the switch unit is now also available with an optional rigid sun visor to protect the buttons from glare when mounted horizontally.

Its wrap around, non-slip, rubber casing that surrounds the switch unit results in a robust, hard wearing, professional switch solution.

The unit is available with 16 small buttons, 15 buttons (14 small and one double) or 14 buttons (12 small and 2 double) with the appropriate legend and key colour as standard, however, by combining 2 small buttons to make 1 large button the unit can have as few as 8 buttons if required. Additionally any button can be programmed for use as PTT (Push To Talk) when activating the built-in microphone.

New and improved features:

- Removable plastic fascia grid allows customers to fit own legend sets or update post installation
- Double and single switches clearly defined by fascia grid
- Legend slippage eliminated as securely fixed between the fascia grid and switch unit by way of 2 small screws
- Proven and established electronics and switch technology
- 14, 15 or 16 buttons, two buttons join together to make one large button that can have dual functions to make a 14 or 15-Way handset
- Small buttons can have a dual function increasing versatility
- Button colours are defined by the LED back light, therefore they have no colour when the switch unit is 'Off'
- Optional programmable PTT (push-to-talk)
- Available as a vertical handset or as horizontal switch unit with/without a sun visor to protect against glare
- All configurations compatible with the full range of MCS Control Units

Overall dimensions:

153mm (h) x 51mm (w) x 20mm (d)

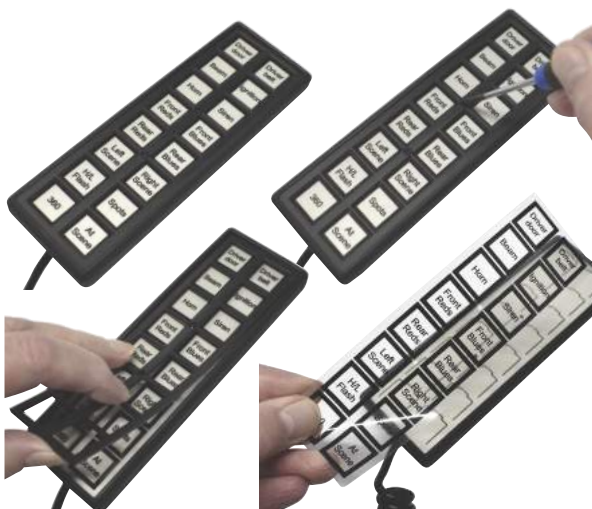

HEND HELD

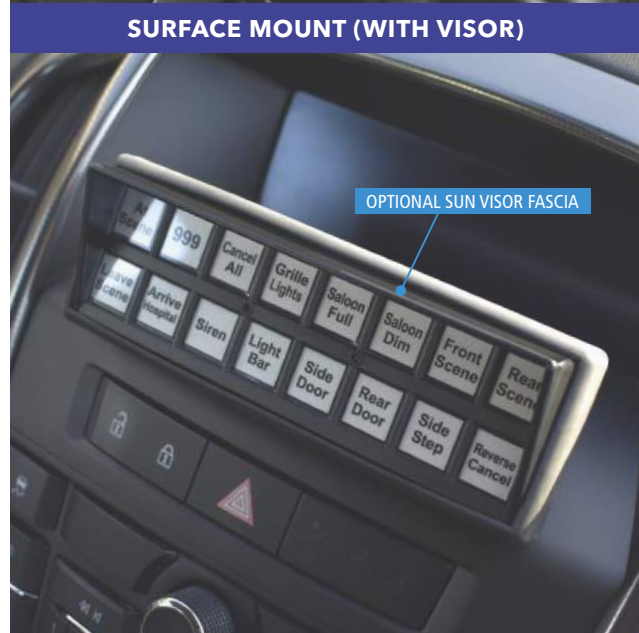

SURFACE MOUNT (WITH VISOR)

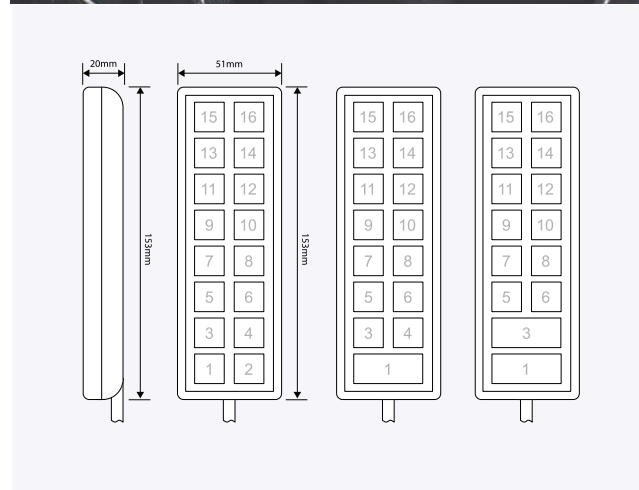

T17 Handset UNI-HAP-XXX

The T17 Handset is a 16-Way handset that was developed specifically for use with our range of MCS control units matching traditional styling whilst utilising state of the art technology.

The T17 consists of 12 individual function buttons, 2 special buttons (Clear All and Walk Test) and 2 combination buttons based upon established tactile switch technology that can be 'user' programmed to suit a wide variety of applications.

A total of 16 buttons with the appropriate legend and key colour as well as optional PTT (push to talk) via a grab switch on the side of the unit.

This switch unit is designed to be mounted adjacent to the vehicle centre console via a microphone type clip and bracket.

A removable, rubber surround encases the unit resulting in a robust, hard wearing, professional switch solution.

- 16 buttons
- Small buttons can also have dual functions
- Button colours are defined by the LED back light, therefore they have no colour when the handset is 'Off'
- Optional PTT (push-to-talk) grab switch
- Compatible with the full range of MCS Control Units

Overall dimensions: 162mm (h) x 71mm (w) x 19.5mm (d)

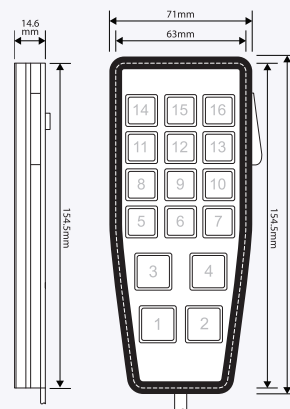

T17 Display Handset UNI-DIS-XXX

The T17 Display Handset has been designed to incorporate and display real-time primary and secondary battery voltage levels.

Its blue on black graphic display allows for quick and efficient monitoring and diagnostics of the vehicle battery sources regardless of lighting.

This multi-way handset is equipped with a total of 16 buttons, 12 of which are individual function buttons, 2 are special buttons (Clear All and Walk Test) and 2 combination buttons based upon established tactile switch technology that can be 'user' programmed to suit a wide variety of applications.

This switch unit is designed to be mounted adjacent to the vehicle centre console via a microphone type clip and bracket.

A removable, rubber surround encases the unit resulting in a robust, hard wearing, professional switch solution.

- 16 buttons
- Blue on black illuminated display for primary and secondary battery voltage levels
- Small buttons can also have dual functions
- Button colours are defined by the LED back light, therefore they have no colour when the handset is 'Off'
- Compatible with the full range of MCS Control Units

Overall dimensions: 162mm (h) x 71mm (w) x 19.5mm (d)

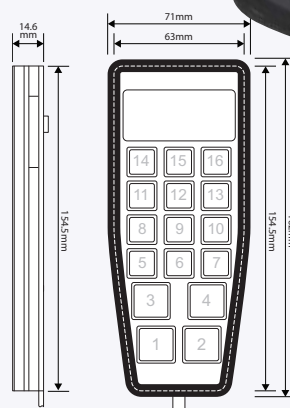

F5 Slimline Switch Units

Available as a 5-Way, 10-way and 15-way switch unit combining a selection of small and large buttons

The single F5 Slimline Switch Unit was developed to sit alongside an MDT unit. While the dual and triple versions are designed to sit at the top of the dash board thereby reducing the clutter that is inevitable within General Purpose and Fast Response emergency services and utility vehicles.

F5 Single Switch Units:

F5 Single Switch Units consist of 5 buttons (5 small or 4 small and one large) with appropriate legends and key colours. It can be formatted vertically or horizontally as required.

This switch unit was primarily designed for permanent mounting on the dashboard, however it is now supplied complete with a complimentary rubber shroud that effectively allows the unit to be used as a handset. It also has a moulded channel around the edge of the shroud to allow the unit to be set into the bodywork if required.

F5D Dual Switch Units:

The F5D dual Switch unit consist of 10 buttons (8 small or 2 large) with appropriate legends and key colours.

The unit is permanently mounted in an appropriate place on the dashboard, ideally above the radio DIN slot or on top of the dash with a custom made mounting bracket (not supplied).

F5T Triple Switch Units:

The F5D dual Switch unit consist of 15 buttons (13 small or 2 large) with appropriate legends and key colours.

The unit is usually permanently mounted on top of the dash with a custom made mounting bracket (not supplied).

General Features:

Public address for all F5 switch units would be implemented via a separate hand held microphone with integral PTT switch.

- Buttons can also have dual function increasing versatility
- Button colours are defined by the LED back light, as they have no colour and are unlit when the unit is 'off'
- For PTT use Universal Hand Held Microphone (UNI-MIC-005)
- All configurations compatible with the full range of MCS Control Units

F5: HEND HELD OR SURFACE MOUNT



F5D: SURFACE MOUNT



F5T: SURFACE MOUNT



F5:

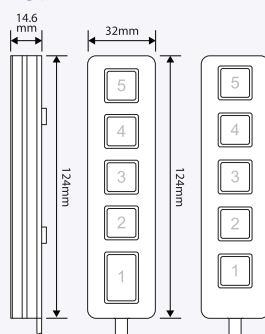

F5D:

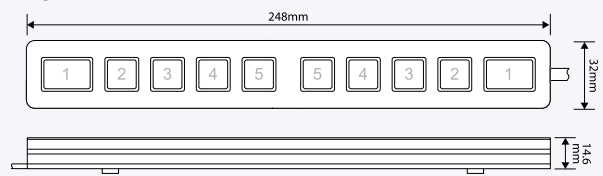

F5T:

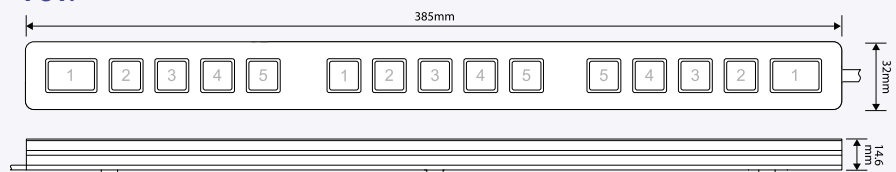

F14 Maxi Switch Unit UNI-MAX-XXX

Available as a 14-Way and 13-Way DIN/Surface mount switch unit as standard, also configurable between 7 and 12 buttons.

The F14 Maxi Switch Unit was developed to fit within a standard radio DIN slot. It is available as a 13-Way and 14-Way switch unit as standard, but can also be configured to have between 7 and 12 buttons if required.

This switch unit has 3 versions available which consist of a 14 small button version or a 14 button version with 12 small and 2 larger buttons and a 13 button version with 12 small buttons and 1 double button, with appropriate legends and key colours.

The F14 can be formatted vertically or horizontally as required. It can be set into the vehicle dashboard via the radio DIN slot for a flush fit or mounted onto it via the two M4 threaded inserts and a mounting bracket (not supplied) or fix directly to the surface.

Public address would be implemented via a separate hand held microphone with integral PTT switch.

- 14 small buttons or 12 small and 2 large buttons or 12 small buttons and 1 double button
- Buttons can also have dual function increasing versatility
- Button colours are defined by the LED back light, as they have no colour and are unlit when the unit is 'off'
- Permanent mount only
- For PTT use the Hand Held Microphone (UNI-MIC-005)
- All configurations compatible with the full range of MCS Control Units

Overall dimensions: 46mm (h) x 176mm (w) x 14.6mm (d)

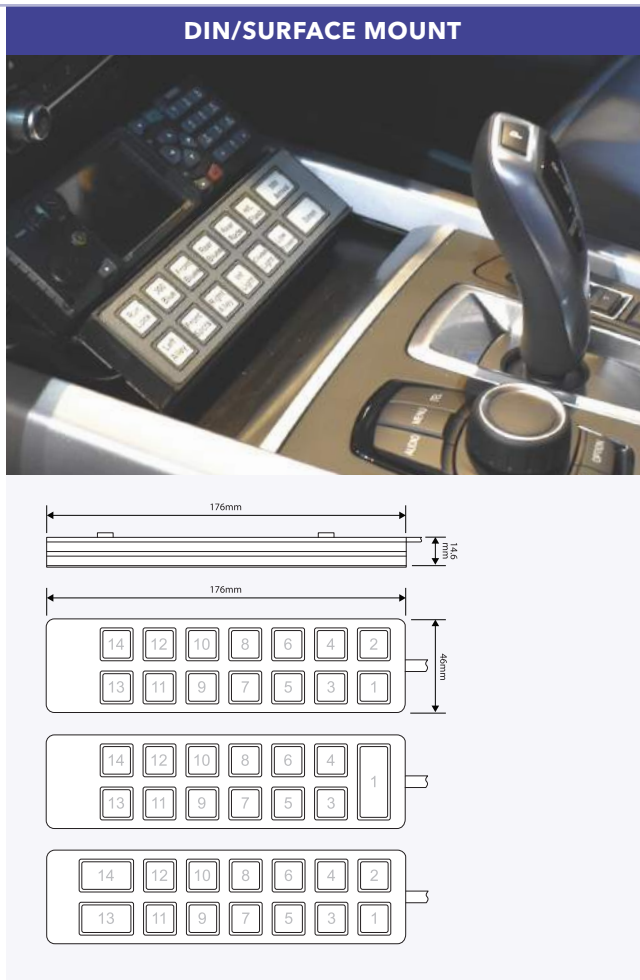

F16 MaxiPlus Switch Unit UNI-MXF-XXX

Available as a 16-Way and 15-Way DIN/Surface mount switch unit as standard, also configurable between 8 and 14 buttons.

The F16 Maxi Switch Unit was developed to fit within a standard radio DIN slot. It is available as a 16-Way and 15-Way switch unit as standard, but can also be configured to have between 8 and 14 buttons if required.

This switch unit has 2 versions available which consist of a 16 small button version or a 15 button version with 14 small and 1 large button with appropriate legends and key colours.

The F16 can be formatted vertically or horizontally as required. It can be set into the vehicle dashboard via the radio DIN slot for a flush fit or mounted onto it via the two M4 threaded inserts and a mounting bracket (not supplied) or fix directly to the surface.

Public address would be implemented via a separate hand held microphone with integral PTT switch.

- 16 small buttons or 14 small and 1 large button
- Buttons can also have dual function increasing versatility
- Button colours are defined by the LED back light, as they have no colour and are unlit when the unit is 'off'
- Permanent mount only
- For PTT use the Hand Held Microphone (UNI-MIC-005)
- All configurations compatible with the full range of MCS Control Units

Overall dimensions: 46mm (h) x 176mm (w) x 14.6mm (d)



F21 Mega20 Switch Unit UNI-MUL-XXX

The F21 Mega20 Switch Panel is a custom designed, vehicle specific unit that was developed for use in the console of a Skoda Octavia Scout where the ashtray is removed and the switch unit is set into the remaining space. Therefore if quantities of units required justify the commercial outlay custom designed units are available for any make and model of vehicle.

Although the Mega 20-Way Switch Panel has an array of 15 simple switch actions it also has 5 illuminated indicators to show the status of certain vehicle conditions.

A diagram showing the function of each key is shown below, from this you will see that some keys can initiate more than one function. A good example of this is the '999' button, when pressed it turns on several functions at once usually when the vehicle and its officers are responding to an emergency (999) situation.

As with other handsets and switch units in the range the buttons are back illuminated in a colour of your choice.

- 15 small buttons and 5 indicator buttons
- Small buttons can also have dual function increasing versatility
- Button colours are defined by the LED back light, as they have no colour and are unlit when the unit is 'off'
- Permanent mount only
- For PTT use the Hand Held Microphone (UNI-MIC-005)
- Compatible with the full range of MCS Control Units

Fascia dimensions: 84mm (h) x 150mm (w)

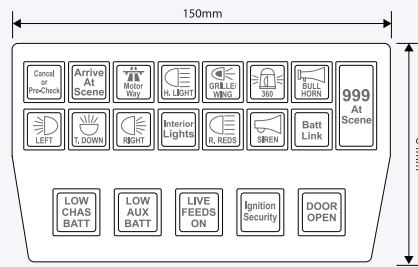

Hand Held Microphone

UNI-MIC-003 for use with MCS-SE 100w Siren

UNI-MIC-005 for use with MCS range of Control Units

The microphone offers extremely low sensitivity to hum pick-up and low susceptibility to radio frequency interference.

They fit naturally and comfortably in the hand and are not adversely affected by heat or humidity. The moulded plastic case is immune to oil, grease, fumes, salt spray, sun, rust and corrosion, and is outstanding in its ability to withstand mechanical shocks and vibration.

- UNI-MIC-003 - dynamic microphone without pre-amp
- UNI-MIC-005 - dynamic microphone with pre-amp
- Frequency response from 200Hz to 3000Hz
- Profiled and optimised for voice communications
- Low susceptibility to radio-frequency interference
- Durable curly cord for professional use
- Low sensitivity to hum
- Supplied with a 1m curly cord that extends to 3m

HAND HELD MICROPHONE COMPONENTS	
PART NO.	DESCRIPTION
UNI-MIC-003	Microphone for MCS-SE Siren
UNI-MIC-005	Microphone for MCS control units
13-1250	Microphone Mounting Clip - Dash Half (spare)
19-1394	2 metre extension lead
19-1346	6 metre extension lead



Handset and Microphone Adaptor
ACC-236

Used to connect additional handsets and/or fist mic's to MCS control devices

Handset Hub
ACC-327

Used to connect additional handsets and/or expansion units to MCS control devices.

Panel Mount Microphone
Pre-wired panel mount electret microphone and pre-amp for use with the MCS-AIC and MCS control devices.

UNI-MIC-007 - for use with MCS-AIC
KIT-247 - UNI-MIC-007 complete with 2m cable - for use with MCS devices
KIT-257 - UNI-MIC-007 complete with 6m cable - for use with MCS devices

T8A Mini Switch Panel UNI-MIN-XXX

The T8A Mini Switch Panel is based on the popular T8 Handset. This version was developed to be set into the vehicle dash or panelling.

This unit has a black cast aluminium casing for a long lasting, hard wearing switch solution.

This switch unit has 8 small dual function buttons with appropriate legends and key colours.

Public address would be implemented via a separate hand held microphone with integral PTT switch.

- 8 small buttons
- Buttons can also have dual function increasing versatility
- Button colours are defined by the LED back light, as they have no colour and are unlit when the unit is 'off'
- Permanent mount only
- For PTT use the Hand Held Microphone (UNI-MIC-005)
- Compatible with the full range of MCS Control Units

Overall dimensions: 120mm (w) x 68mm (h) x 15mm (d)

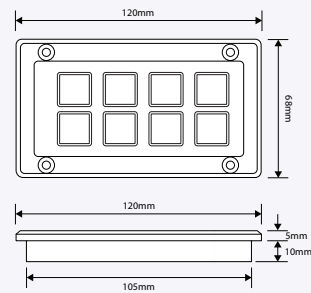

INSET

T16A MaxiPlus Switch Panel UNI-MXP-XXX

The T16A MaxiPlus Switch Panel is based on the popular T16 Handset. This version was developed to be set into the vehicle dash or panelling.

This unit has a black cast aluminium casing for a long lasting, hard wearing switch solution.

This switch unit has 16 small dual function buttons with appropriate legends and key colours.

Public address would be implemented via a separate hand held microphone with integral PTT switch.

- 16 small buttons
- Buttons can also have dual function increasing versatility
- Button colours are defined by the LED back light, as they have no colour and are unlit when the unit is 'off'
- Permanent mount only
- For PTT use the Hand Held Microphone (UNI-MIC-005)
- Compatible with the full range of MCS Control Units

Overall dimensions: 160mm (w) x 68mm (h) x 15mm (d)

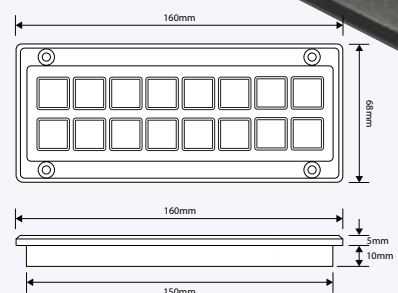

INSET

P12 MidiPlus Switch Panel UNI-MDP-XXX

The P12 MidiPlus Switch Panel was developed to be set into the vehicle dash or panelling of larger emergency services and utility vehicles such as fire appliances.

This switch unit has 12 large dual function buttons that are approximately 25% larger than those on a standard switch unit, with appropriate legends and key colours.

This unit has a black cast aluminium casing for a long lasting, hard wearing switch solution.

Public address would be implemented via a separate hand held microphone with integral PTT switch.

- 12 large buttons
- Buttons can also have dual function increasing versatility
- Button colours are defined by the LED back light, as they have no colour and are unlit when the unit is 'off'
- Permanent mount only
- For PTT use the Hand Held Microphone (UNI-MIC-005)
- Compatible with the full range of MCS Control Units

Overall dimensions: 204mm (w) x 73mm (h) x 17mm (d)

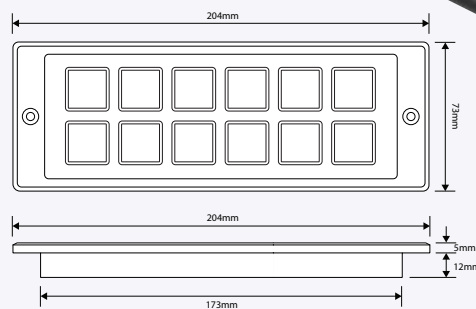
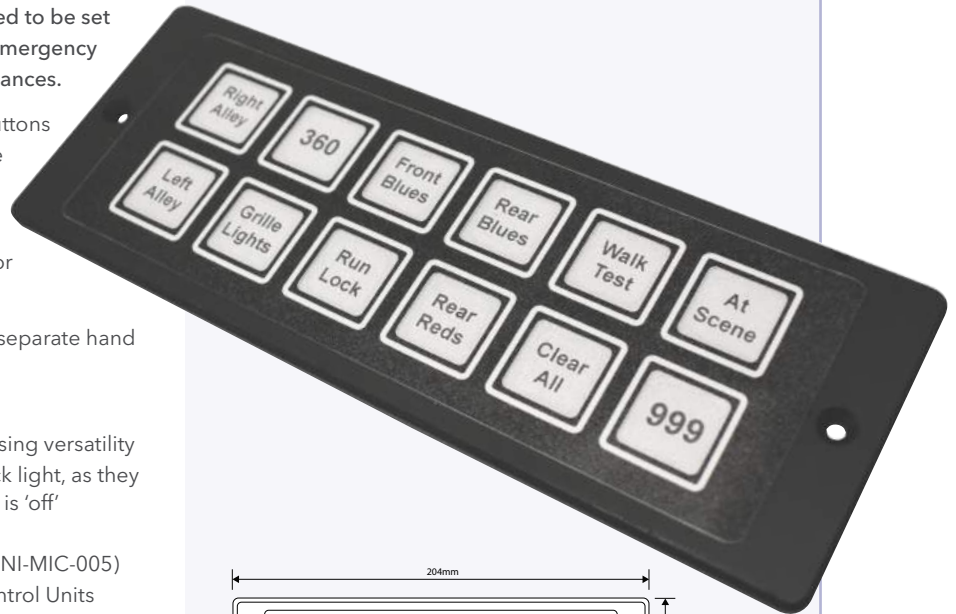

INSET

P16 MaxiPlus Switch Panel UNI-MXF-XXX

The P16 MaxiPlus Switch Panel was developed to be set into the vehicle dash or panelling of larger emergency services and utility vehicles such as fire appliances.

This switch unit has 16 large dual function buttons, that are approximately 25% larger than those on a standard switch unit, with appropriate legends and key colours.

This unit has a cast aluminium casing for a long lasting, hard wearing switch solution.

Public address would be implemented via a separate hand held microphone with integral PTT switch.

- 16 large buttons
- Buttons can also have dual function increasing versatility
- Button colours are defined by the LED back light, as they have no colour and are unlit when the unit is 'off'
- Permanent mount only
- For PTT use the Hand Held Microphone (UNI-MIC-005)
- Compatible with the full range of MCS Control Units

Overall dimensions: 255mm (w) x 73mm (h) x 17mm (d)

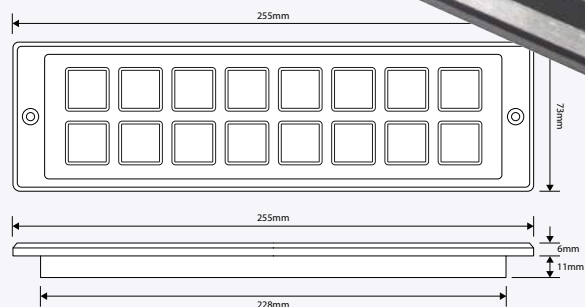
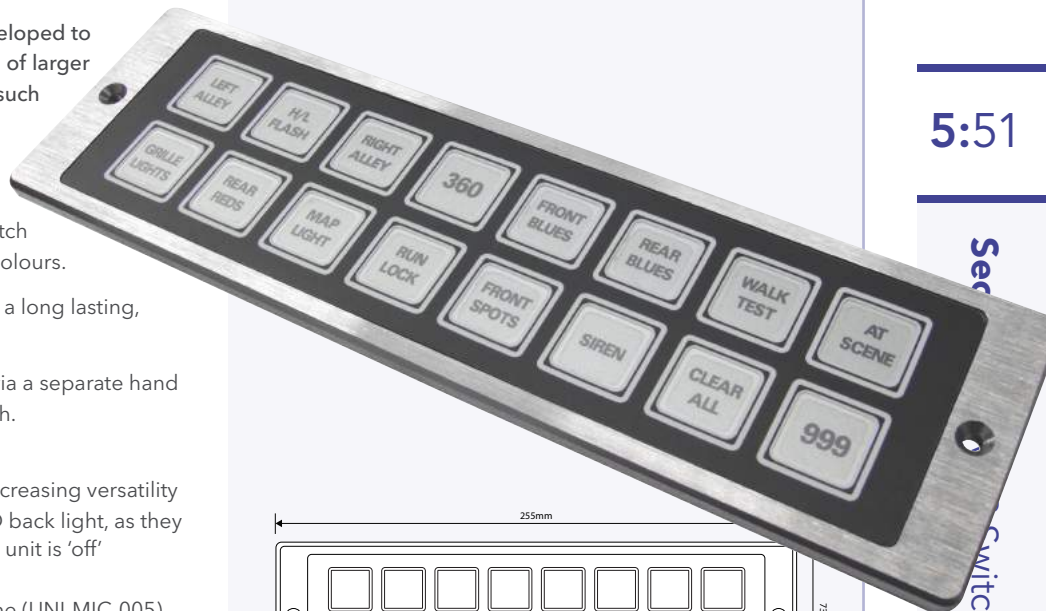

INSET

5:51

Sec
Switch Units & Panels

MCS-TSC Touch Screen Controller

Program to suit single or multi layered applications.

Standard ready-made layouts available, custom layouts available on request.

PRODUCT OVERVIEW

The MCS Touch Screen Controller is a Hi-Tech alternative to traditional MCS switch panel solutions to give users direct control over their switch function requirements.

The screen can detect the presence and location of touch on the display area by finger pressure or sense any passive objects including a stylus or even a gloved finger.

Along with the intuitive touch screen there are 4 built-in direct access buttons for all primary functions in the unlikely event of screen failure.

By utilising pre-defined formats customers are able to change screen button text to match their specific requirements without having to involve Standby RSG.

For applications requiring a more in-depth solution Standby RSG can work with clients on mutually commercially viable projects to develop bespoke solutions for precise end application.

When the touch screen is initially powered up the most commonly required screen will appear, or if preferred and more appropriate this can be a home screen. However, as the screen will normally show up to 4 tabs across the top these effectively negate the need for a home screen for simple applications as illustrated by the examples shown.

As the operational concept of the Touch Screen Display is based on having a unique screen layout for each application, each layer can be assigned a level of importance (priority) so it may be accessed easily as required.

Absolute Maximum Ratings

Supply Voltage: 18 Volts DC

Supply Current: 1.5 Amps

Electrical Characteristics

Operating Voltage: 12 Volts DC

Standby Current: 100 Milliamps

Temperature

Standby Temperature: -20 Deg C to +70 Deg C

Operating Temperature: -20 Deg C to +50 Deg C

Typical Applications:

- Switch Panel Screen - Blue's and Two's
- Battery Monitoring Screen
- Dog Kennel Monitoring Screen
- Prisoner Cell Temperature Screen
- Walk Test Screen
- Locker Check Screen
- Pre-Drive Check Screen

The MCS Touch Screen would normally be used in conjunction with the following MCS devices:

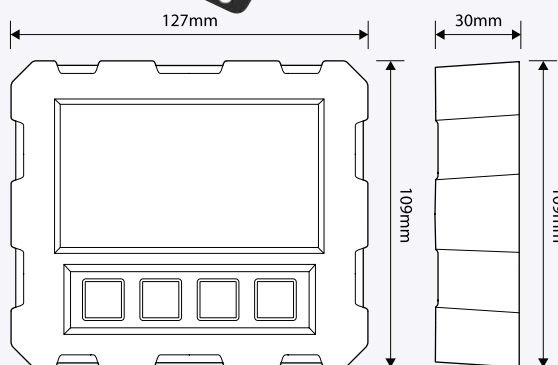

MCS-TSC TOUCH SCREEN CONTROLLER	
PART NO.	DESCRIPTION
UNI-TSC-XXXX	Touch Screen Controller
UNI-TSC-PAN	Panel Mount Kit for Touch Screen Controller
UNI-TSC-BKT	Adjustable Mounting Bracket for Touch Screen Controller



TYPICAL SCREEN LAYOUTS - MCS DEVICES

By utilising pre-defined formats customers are able to change screen button text to match their specific requirements



DISPLAY AREA TEMPERATURE



DISPLAY BATTERY VOLTAGE



TYPICAL HAZARD WARNING SCREEN



TYPICAL TEST SCREEN

TYPICAL SCREEN LAYOUTS - COMPLIMENTARY DEVICES

By utilising pre-defined formats customers are able to change screen button text to match their specific requirements



200W DIGITAL SIREN AMPLIFIER



TRAFFIC COMMANDER PROGRAMMABLE LED MATRIX DISPLAY



5:53

Section 5 : MCS Switch Units & Panels

Public Address (PA) Systems

Auto Recall Units - Solid State Voice Recording Announcers

Two versions of these high quality public address devices are available - Standard and High Power Output - to audibly inform and instruct crowds, groups or individuals.

- **Standard:** 2 x 22W audio outputs for local announcements
- **High Power:** 1 x 60W (80W equivalent) audio output for broader general announcement

Both types of units have the facility to record and re-broadcast messages up to 60 seconds in length, where the recorded messages are stored on a solid state memory system meaning that there is no tapes or moving parts to malfunction as well being immune to vibrations associated with mobile vehicle applications.

Common Features:

Inform and Instruct - The 'Auto Recall' unit is a high quality public address amplifier with the facility to record and re-broadcast messages up to 60 seconds in length. Recorded messages are stored on a solid state electronic memory system, meaning there are no tapes or moving parts to go wrong.

Auto Message Repeat - Auto repeat facility means drivers can concentrate on the road without having the microphone in their hand.

Public Utilities - Now established as an essential tool with utility companies, the Auto Recall is an invaluable piece of equipment both for routine and emergency announcements.

Emergency Services - Control incidents or prevent them from occurring by informing the public of your intentions, or by instructing them what to do.

Flood Warning - Inform the public clearly and concisely what is going on. Announce evacuation procedures or simply organise the appropriate action to be taken.

Promotional and Political Campaigns - The ideal tool to get your message across to sell your ideas, products or simply increase your popularity.

Making your Presence Known - To make visual as well as audio impact a comprehensive range of illuminated roof signs with integral speakers are available. The ideal accompaniment to the Auto Recall Unit. A range of light bars and magnetic speakers is also available.

- All solid state electronics. No tapes or moving parts to malfunction
- Record, rebroadcast and auto message repeat facility
- Optimised for 12v operation, can be used on a 24v vehicle with suitable voltage dropper



Standard Auto Recall Unit AUT-110

All-in-1 construction
Fits into standard radio DIN slot
Standard Microphone
Preview Speaker: Built-in
12 Volt operation
3 Amps Maximum
2 x 22 Watt Audio Outputs
115dB @ 1 metre @ 1KHz
Complete Unit: 115mm (d) x 178mm (w) x 53mm (h)
2 x 8 Ohm 30 or 40 Watt Speakers Required



High Power Auto Recall Unit AUT-500

2 unit construction
Dash mount switch unit and discreet mount power amplifier
Rugged Microphone
Preview Speaker: Separate Unit
12 Volt operation
6 Amps Maximum
1 x 60 Watt (80W equivalent) Audio Output
120dB @ 1 metre @ 1KHz
Control Switch Unit: 19mm (d) x 147mm (w) x 56mm (h)
Power Amplifier: 32mm d) x 78mm (w) x 32mm (h)
1 x 4 Ohm 60 Watt Speaker Required

Revolution PA Lightbar

40W - RVC-004-0003 60W - RVC-003-0003

The Revolution PA Lightbar is a 29" (733mm) LED lightbar that has been developed specifically for use with both the standard 40W and high power 60W Auto Recalls units.

The circular LED modules have 12 ultra-bright LEDs within them. These modules are ECE R65 approved with a 130fpm triple flash pattern imitating a rotator for 360° light output.



Tornado PA Lightbar

PTX-124

The Tornado PA Lightbar is a 39" (1000mm) LED lightbar with two 40W speakers for use with the standard 40W Auto Recall unit.









Circular LED beacon modules with 12 ultra-bright LEDs are set at each end of the lightbar for true 360° light output. These beacon modules are ECE R65 approved with a fps flash pattern for maximum visibility.



Loudspeakers for PA Systems and dB Ratings

We have a selection of speakers from 20 Watts up to 60 Watts supplied with unterminated wires that are compatible with our standard and high power Auto Recall Unit. See table below for more information.

Compatibility Selection Chart

Type	40 Watt Standard Loudspeaker	30 Watt Standard Loudspeaker	30 Watt Magnetic Standard Loudspeaker	60 Watt High Power Loudspeaker
				
Colour	Black	White	White	Black
Part Number	11-1001	11-1003	LSP-201	11-1031
Construction	Weatherproof black plastic horn	Weatherproof white plastic horn	Weatherproof white plastic horn	Weatherproof black metal horn
Description	Adjustable mounting bracket 40 Watts, 8 Ohms 300Hz to 10KHz	Adjustable base plate 30 Watts, 8 Ohms 200Hz to 8KHz	Adjustable base plate 30 Watts, 8 Ohms 200Hz to 8KHz	Fixed mounting bracket 60 Watts, 4 Ohms 300Hz to 8KHz
Dimensions	113mm deep 110mm wide 130mm high	234mm deep 200mm wide 106mm high	234mm deep 200mm wide 106mm high	85mm deep 135mm wide 148mm high
Compatible Auto Recall Unit	Standard Auto Recall Unit AUT-110 2 x 22 Watt Output	Standard Auto Recall Unit AUT-110 2 x 22 Watt Output	Standard Auto Recall Unit AUT-110 2 x 22 Watt Output	High Power Auto Recall Unit AUT-500 1 x 60 Watt Output
				
	Can use 1 or 2 speakers 2 highly recommended 115.0dB @ 1 metre 2 x speakers	Can use 1 or 2 speakers 2 highly recommended 115.0dB @ 1 metre 2 x speakers	Can use 1 or 2 speakers 2 highly recommended 115.0dB @ 1 metre 2 x speakers	Can only drive 1 speaker 120dB @ 1 metre 109.9dB @ 7 metre Equivalent to 80 Watt dB rated device

- Note:
- The dB rating (loudness) is primarily a function of the Auto Recall amplifier rating and secondly the ability of the speaker to convert electro-mechanical energy into sound waves
 - The loudspeaker Wattage is not an indication of how much sound, in terms of dB's, is produced by the system as this directly relates to the PA amplifier output
 - All tests conducted at 1 KHz

Budget PA System - 15W PAA-132

The Budget PA System is ideal for remote applications requiring a compact and powerful amplifier for public address or emergency paging.

Powered via a standard external 12 Volt DC battery (usually on a vehicle) it can operate into four or eight Ohm speaker loads. It includes two audio inputs with individual volume controls, a single handheld microphone with talk switch, and an auxiliary input for connecting an external CD player, radio or tone generator.

All mounting hardware is included for easy installation under dashboard or into a standard radio DIN slot.

Supplied complete with unidirectional, dynamic-type hand held microphone with talk switch, extendable cord and mounting hardware.

- Supports 4 or 8 Ohm speaker loads, 15W power output at 4/8 Ohms
- Less than 3 Amps current consumption
- 100 Hz - 10 kHz (± 3 dB) frequency
- Five year warranty

Overall dimensions: 170mm (d) x 178mm (w) x 50mm (h)



Run Lock Options

Run Lock-2 RUN-102-03

For vehicles with traditional electro-mechanical ignitions

A conventional 2 output Run Lock Device with 'Activated' indicator lamp operating at 12/24v.

A Run Lock unit is designed so that a vehicle can be left with the engine running to power radios, lights and other ancillary devices without the battery going flat.

By making use of two ancillary outputs the Run Lock-2 system is ideal for use on vehicles with a 'conventional' electro-mechanical ignition switch where the 'live' input connection can be shorted to the output terminal, via a relay contact, such that the vehicle ignition remains 'on' when the key is in the 'off' position or completely removed.

Operation

When the engine is running and the vehicle is stationary with the handbrake applied; the run lock switch is pressed, activating the run lock. This provides power to the main ignition and to two ancillary outputs allowing the ignition key to be turned off and removed.

The vehicle cannot be driven off, because as soon as the hand break is removed or the foot break is applied, the run lock is disabled and the engine will stop. The run lock switch should be momentary action with push to make contacts.

Overall dimensions: 43mm (d) x 80mm (w) x 39mm (h)



Run Lock Solutions

For vehicles with CAN based ignitions

General Characteristics

A Run Lock allows the operation of a vehicles engine to continue with the ignition key removed providing certain conditions are met: A manual request, by physically operating a switch, must be made in conjunction with the handbrake being on and in certain circumstances the doors locked to permit activation.

Activation and Operation

Practical implementation of the Run Lock is very much down to the age, make and model of the vehicle requiring a Run Lock device.

In its simplest form, a Run Lock activation switch is operated, which in turn energises a relay, who's contacts then put an 'electrical short circuit' across the ignition barrel contact. Thus allowing the engine to continue to run when the ignition is turned off position and key removed to lock the vehicle doors and thereby avoiding theft.

Generally speaking as most vehicles now have a CAN Bus based data communication system between functions, such as between Ignition Switch, Engine Control Unit (ECU) and Central Locking Unit, a vehicle specific CAN Bus based device is required. However, as Standby RSG offers a full range of vehicle warning light and audio controllers that have CAN Bus interfaces these can sometimes be used to implement Run Lock on particular vehicles to save the cost of an additional 'vehicle specific' device.

In order to obtain a more elegant and sophisticated solution Run Locks are generally activated by physically operating a manual switch that is often part of a multi-way switch panel rather than a stand alone device. Also, a Run Lock is only allowed to be activated if certain vehicle conditions are present such as Hand Brake on and all doors locked with windows shut. Then for safety and anti-theft reasons an over-ride facility is required to turn-off (stop) the engine if one of the actions listed occurs.

- Doors opened
- Foot Brake Pedal is operated
- Hand Brake Lever is operated
- Clutch Pedal is operated

In addition other features are sometimes required.

- Time out function after switch is operated to take system out of Run Lock mode once a set period of time has passed - say 30 seconds
- Vehicle doors are automatically locked a set period of time after the Run Lock has been activated and/or the doors being closed
- Operates in conjunction with the vehicles remote locking system and does not impede its normal operation
- Take account of vehicles with keyless ignition systems and/or proximity locking services
- Interfaces with other equipment to automatically initiate its operation which typical could be a 'Gateway Radio' system often used in cities

Contact our sales department for a list of current vehicle specific devices in terms of make and model.

Traditional Method by Shorting Contact

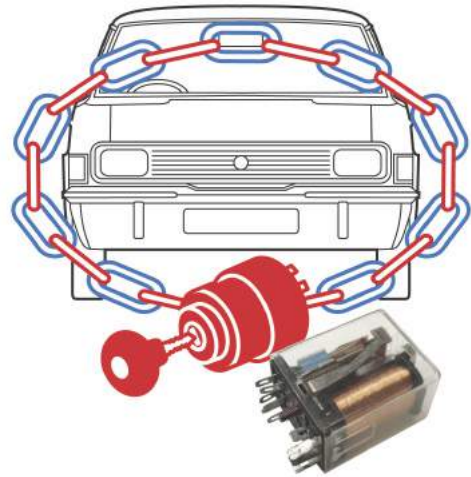

Contemporary Method CAN BUS Manipulation

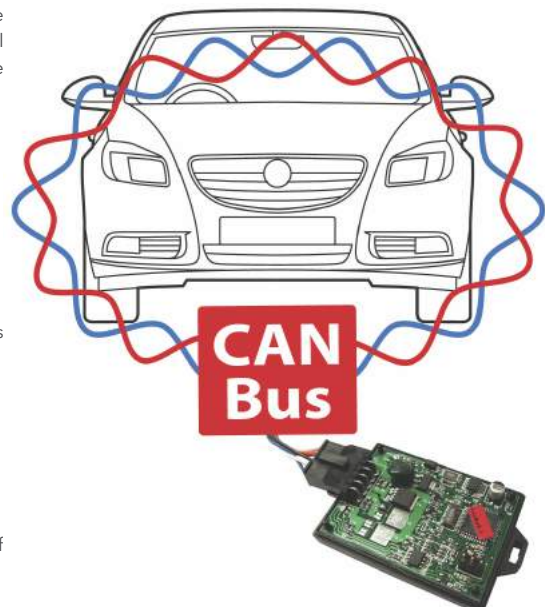

Add-on or Stand-alone Units

Headlight Flash-2 SWT-240-01

The NEW Headlight Flash-2 is an easy to understand, install and use device that is capable of making the headlights flash on almost any vehicle.

- 2 x 20 amp relays to perform various flash routines
- Various flash patterns including a haphazard flash pattern to suit different lamp characteristics
- 12v operation via 20 amp fused feed
- Separate start/stop sense control
- Night time override sense control
- Electronics are reverse polarity protected
- Unit is transient protected
- Less than 25mA standby current
- Alternating or synchronised flash
- Each output will flash 2 x 55W halogen bulbs

Overall dimensions: 55mm (d) x 110mm (w) x 45mm (h)



Mini Flasher Unit SWT-305-03

This new solid state Mini Flasher is a compact unit that has semi conductor switching eliminating the need for relays.

- Ideal to flash LED light heads (without built-in controller) and/or head lamps
- Two independent outputs for off-side and near-side switching
- Two separate inputs to switch between 'steady' and 'pause' modes
- 11 Selectable flash patterns
- Built-in diagnostic LEDs to indicate flash patterns
- Each channel can switch a maximum of 10 Amps
- Fully encapsulated with waterproof connector
- Comes complete with 1 metre cable loom
- Cast aluminium casing acts as an effective heat sink
- 12 or 24 volt operation

Overall dimensions: 35mm (d) x 83mm (w) x 27mm (h)

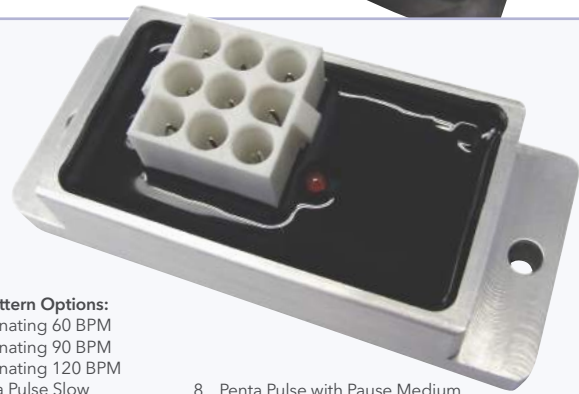

Flash Pattern Options:

- 1 Alternating 60 BPM
- 2 Alternating 90 BPM
- 3 Alternating 120 BPM
- 4 Penta Pulse Slow
- 5 Penta Pulse Medium
- 6 Penta Pulse Fast
- 7 Penta Pulse with Pause Slow
- 8 Penta Pulse with Pause Medium
- 9 Penta Pulse with Pause Fast
- 10 Multi Flash - Combination with Alternating Flash
- 11 Cyclic - Combination of Penta and Alternating Flash

Mini Dimmer Unit

A solid-state compact unit that has semi conductor switching eliminating the need for potentiometers and relays. This operates either as a stand alone device or can be used with an MCS-32 or 16 device to 'dim' or 'brighten' LED light heads either as individual light heads or groups of lamps.

- Ideal to dim or brighten individual LED light heads or groups of lamps
- Typically 2 x output channels for 'enable' and 'brightness up/down' control
- Typically 2 x input channels for 'brightness up/down' control
- Effectively 10 x brightness/dim levels
- Built-in diagnostic LED
- Each channel can switch a maximum of 10 Amps
- Fully encapsulated with waterproof connector
- Comes complete with 1 metre cable loom
- Cast aluminium casing acts as an effective heat sink
- 12 or 24 volt operation

Overall dimensions: 35mm (d) x 83mm (w) x 27mm (h)



MCS-DMC MINI DIMMER UNIT

PART NO.	DESCRIPTION
UNI-DMF-003	Mini Dimmer - MCS Controlled Version
UNI-DMF-002	Mini Dimmer - Manual Wired-in Version

Indicator Inhibitor Kit UNI-DMF-001

The Indicator Inhibitor module is a small device which allows LEDs (flashers) fitted in indicator clusters to be inhibited (interrupted) when the appropriate indicator is activated as part of the vehicles normal operation. The device can be used in conjunction with any 12v switched output or directly connected to the vehicle supply.

- 3 x inputs
 - Input 1: Unit enabled
 - Input 2: Left indicator
 - Input 3: Right indicator
- 2 x output channels can switch a maximum of 2.5 Amps
 - Left flasher/LED
 - Right flasher/LED
- Built-in diagnostic LED
- Each channel can switch a maximum of 10 Amps
- Fully encapsulated with waterproof connector
- Comes complete with mating connectors and cable loom
- 12 or 24 volt operation

Compatible for optional use with our MCS-Mini, Midi and Maxi and legacy CVS-12 installations or refits. Note, this feature is in-built in the MCS-32 and 16.

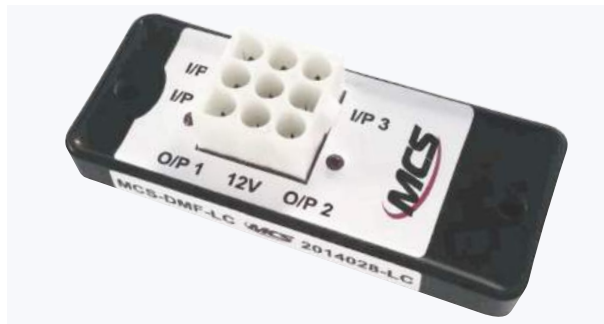

Battery Guard 2000 Controls Power Protects Profit



A battery guard constantly monitors available battery power when the engine is not running and automatically disconnects when voltage drops below a critical level.

PRODUCT OVERVIEW

Flat batteries are still the number 1 cause of vehicle down time across all automotive sectors. As electrical specifications on vehicles continue increase installing a system that provides a guarantee of starting is a sensible and financially viable approach to this perennial problem.

The Battery Guard 2000 constantly monitors the available battery power when the engine is off. If the battery voltage drops below 12.1V or 24.1V a voltage sensitive timer is triggered within the ECU.

If the available battery voltage remains below 12.1V or 24.1V for a full four minutes, the battery will automatically be isolated to guarantee starting power.

At this stage there will be no power for ignition, the vehicle operator must press the flashing reset switch and restart the engine. Battery Guard 2000 also offers the vehicle operator the ability to manually isolate the battery via a reset switch. Simply press and hold the switch for 2 seconds and the battery will be isolated.

Technical Specification:

Nominal operating current	12 volts	24 volts
Actuation current	3.0 amps	1.2 amps
Minimum actuation voltage	9 volts	18 volts
Maximum continuous carry current	100 amps	100 amps
Maximum carry current (30 secs)	500 amps	500 amps
Ambient temperature range	-40° to +85°C	-40° to +85°C
Normal input voltage range	10-16 volts	20-32 volts
Contact life at full load	min 10k cycles	min 10k cycles
Standby current	10mA	18mA
Short term over voltage protection to	+24 volts	+36 volts
Reverse voltage protection to	-800 volts	-800 volts
Positive voltage spike protection to	+150 volts	+150 volts
Maximum actuation time	0.2 seconds	0.2 seconds

Key Features:

- Automatic low voltage battery isolator
- Guarantees starting power - vehicle will start first time, every time
- System test on start up
- Provides a means to manually isolate the battery
- Ignition/alternator protected - unit overridden when vehicle engine running
- IP67 rated Electronic Control Unit (ECU) and connectors
- Constantly monitors available battery power when engine is not running
- Manual override switch to enable vehicle start up
- Quick and easy to install
- Approved by Paccar, Iveco, Scania, Dennis, MAN
- e approved

BATTERY GUARD 2000

PART NO.	DESCRIPTION
BAT-115-01	2000 Battery Guard - 100 Amps - 12v
BAT-115-02	2000 Battery Guard - 100 Amps - 24v



Ideal for vehicles used on an ad-hoc or irregular basis

PowerTector Automatic Referencing Solid State Battery Guards

The PowerTector Battery Guard is a solid state automatic referencing battery device that will monitor the source voltage and disconnect the equipment from the vehicle battery if the voltage falls below a pre-determined level. This can work to ensure that there is always sufficient voltage remaining in the battery to start a vehicle engine or ensure power is available for other critical applications. The total discharge of a lead acid battery can also cause damage to the cells significantly shortening the life of the battery. The PowerTector unit can also be set to disconnect equipment at a lower voltage that will still protect the battery from total discharge, while allowing for maximum battery usage. A timed version is also available which automatically disconnects a set period after the ignition has been switched off.



A Wide Range of Features

There are six units in the range from 10A to 200A. The 10A and 20A unit offer a simple in-line system, usually wired to a specific piece of equipment. These units do not require chassis mounting and simply connect and tie wrap neatly within the wiring system. The 40A and 60A units are connected by M6 brass bolts, the 100A and 200A by M10 brass bolts and use a three point mounting system to avoid rocking or stress to the electronics when mounted on uneven surfaces. Heat is dissipated into our custom manufactured die cast casing and all units will operate at full power without additional heatsink dissipation.

Manual Shutdown Facility

From 40A upwards, the units have the facility to be manually shutdown either through the ignition or a dedicated switch. In addition, from 100A upwards the units can have an override switch fitted. This allows the units to be reactivated for four minutes to allow emergency actions to be performed.

Alarm & Disconnect Delay

An alarm output is provided which, once the threshold has been reached for 10 seconds, will activate, sounding an alarm or other indicating device for a further 50 seconds prior to disconnection. This allows the operator to restart the engine or take other action to maintain continuous power. (alarm not provided)

Timed Versions

In addition to the standard PowerTectors, the PT-T versions offer a timed facility. This will disconnect the output after a set time after the ignition has been turned off. If required, during this time period, the voltage can still be monitored and disconnected if it falls below a set level to protect the battery power and system. The unit will reactivate when the ignition has been turned on again and the battery voltage has reached 8.5Vdc (12V systems), 17Vdc (24V systems).

Fully Programmable

All units in the range are supplied pre-programmed for a variety of scenarios offering higher or lower disconnect voltages and it is quick and simple to select the correct programme to suit your needs.

- Automatic referencing - the device automatically adjusts to match the voltage to either a 12 or 24 Volt Battery and sets the appropriate trip levels
- All PowerTectors from 40A upwards are mounted in a die cast aluminium casing with glass filled polycarbonate cover providing terminal protection and insulation
- Smaller units; 10A and 20A, are available in a lightweight, polycarbonate casing that can be simply fitted in the wiring, like an in-line fuse
- Using the simple programming terminal, select the pre-set disconnect voltage according to your requirements
- Green LED indicates operational status
- Audible alarm and/or visual indicator can be installed in the dashboard or cockpit to alert operator of a potential problem
- Switch terminal allows the unit to be operated via the ignition or a manual switch
- The PowerTector battery guards offer excellent protection for communication and other mission critical applications



Input voltage range	9-32Vdc (automatic referencing)
Output voltage	Equal to input voltage when operating (max 100mV drop across terminals)
Transient over current rating (% of continuous value)	110% for 10s, 200% for 1s, 300% for <0.5ms On over current shutdown there is a retry every 30s
Quiescent current when shutdown	PT10/20 Typical 2mA @13.6V, PT40/60 Typical 4mA @13.6V PT100/200 Typical 6mA @13.6V
Transient voltage protection	Meets ISO7637-2 International standard for 24V vehicles
Electrostatic voltage protection	Meets ISO10605, >8kV contact, 15kV discharge
Operating temperature	-25°C to +60°C to meet this specification table
Storage temperature	-25°C to +100°C
Ingress protection	IP65
Case work	Silver anodised aluminium, glass filled polycarbonate
Connections	PT10/20 insulated 6.3mm push-on flat blade connectors, PT40/60 M6 ring tongues, PT100/200 M10 ring tongues. 6.3mm push-in flat blade connectors for earth, switch, override, and alarm. Programming lead with 2.8mm blade connector supplied.
Safe area protection	Over current: Limited by current sensing circuit Over heat: Limited by temperature sensing circuit Transients: Protected by filters and rugged component selection Catastrophic protection: Set by external input fuse and ground line fuse max 1A
Approvals	2014/30/EU The general EMC directive, Regulation 10 The automotive directive, 93/68/EEC The CE marking directive, AES5
Designed to	EN50498, ISO 7637-2

POWERTECTOR BATTERY GUARDS			
PART NO.	DESCRIPTION	VOLTAGE	DIMS
BAT-250-10	PT10 10A Continuous (Auto Ref)	12/24v	155 x 30 x 15mm
BAT-250-10T	PT10-T 10A Continuous (Auto Ref) Timed	12/24v	155 x 30 x 15mm
BAT-250-20	PT20 20A Continuous (Auto Ref)	12/24v	155 x 30 x 15mm
BAT-250-20T	PT20-T 20A Continuous (Auto Ref) Timed	12/24v	155 x 30 x 15mm
BAT-250-40	PT40 40A Continuous (Auto Ref)	12/24v	76 x 78 x 33mm
BAT-250-40T	PT40-T 40A Continuous (Auto Ref) Timed	12/24v	76 x 78 x 33mm
BAT-250-60	PT60 60A Continuous (Auto Ref)	12/24v	76 x 78 x 33mm
BAT-250-60T	PT60-T 60A Continuous (Auto Ref) Timed	12/24v	76 x 78 x 33mm
BAT-250-100	PT100 100A Continuous (Auto Ref)	12/24v	124 x 97 x 51mm
BAT-250-100T	PT100-T 100A Continuous (Auto Ref) Timed	12/24v	124 x 97 x 51mm
BAT-250-200	PT200 200A Continuous (Auto Ref)	12/24v	124 x 97 x 51mm
BAT-250-200T	PT200-T 200A Continuous (Auto Ref) Timed	12/24v	124 x 97 x 51mm

Ideal for vehicles used on an ad-hoc or irregular basis

Pure Sine Wave DC-AC Voltage Inverters

Convert vehicle DC voltage to mains AC voltage

Pure Sine Wave DC-AC Voltage Inverters are protected against overload, short circuit, low and high voltage, over temperature and battery polarity reverse.

They are suitable for a wide range of applications including 7.2 power tools, audio and video equipment, household/kitchen appliances, mobile office equipment and battery chargers as well as being auto, RV and boat compatible.

600 Watt
DCD-184-01



Description

600 Watt, 12v, 50Hz, pure sine wave DC-AC inverter.
Supplied with a single, 3 pin, AC outlet and on/off switch.

Specification
600W power output
1200W output surge power
12v input voltage
220v - 240v output voltage
50Hz output frequency
Pure sine wave output form
0.7A typical efficiency
±6% typical output voltage regulation
10.5V ± 0.5V low battery alarm
10V ± 0.5V low battery shut down
15.5V ± 0.5V high battery shutdown
Fan cooled
60° ± 10° / 140 ± 18°F thermal protection
2 x 35A fuses
One AC outlet

Dimensions

330mm x 170mm x 67mm

1000 Watt
DCD-185-01



Adapted for Remote Switch Extension

Description

1000 Watt, 12v, 50Hz, pure sine wave DC-AC inverter.
Supplied with two, 3 pin, AC outlets and on/off switch.

Specification
1000W power output
2000W output surge power
12v input voltage
220v - 240v output voltage
50Hz output frequency
Pure sine wave output form
1.3A typical efficiency
Output vac +2V ± 5V
10.5V ± 0.5V low battery alarm
10V ± 0.5V low battery shut down
16V ± 0.5V high battery shutdown
Fan cooled
60° ± 10° / 140 ± 18°F thermal protection
4 x 35A fuses
Two AC outlets

Dimensions

390mm x 223mm x 103mm

1500 Watt
DCD-186-01



Adapted for Remote Switch Extension

Description

1500 Watt, 12v, 50Hz, pure sine wave DC-AC inverter.
Supplied with two, 3 pin, AC outlets and on/off switch.

Specification
1500W power output
3000W output surge power
12v input voltage
220v - 240v output voltage
50Hz output frequency
Pure sine wave output form
1.3A typical efficiency
Output vac +2V ± 5V
10.5V ± 0.5V low battery alarm
10V ± 0.5V low battery shut down
16V ± 0.5V high battery shutdown
Fan cooled
50° ± 10° / 122 ± 18°F thermal protection
6 x 40A fuses
Two AC outlets

Dimensions

420mm x 223mm x 103mm

Remote Switch Extension ACC-214

A remote switch extension compatible with the DCD-185-01 1000W and DCD-186-01 1500W Pure Sine Wave DC-AC Voltage Inverters that allows for monitoring and remote activation and deactivation.

The extension is 6 metres in length with an RJ45 connector and an integral switch unit which has 3 indicator lights to signal the power status and overload/over temperature alarm status.

This is an ideal solution if there is little or no available space in the inverter compartment or it is not easily accessible.



Switches and Sundries

Automotive Switches

Round Latching Single Pole

Latching ON/OFF single pole plastic rocker switch.

- 10 Amps @ 12v
- 4.8mm blade terminals
- Snap fit into 20mm diameter hole
- LED indicator on illuminated versions

Dimensions: 23mm (ø) x 20.3mm (d)



PART NO.	DESCRIPTION	VOLTAGE
16-1095	Non-illuminated	12/24v
16-1093	Red LED Illumination - Blank	12/24v
16-1437	Amber LED Illumination - Beacon Symbol	12/24v
16-1438	Amber LED Illumination - Work Lamp Symbol	12/24v

Momentary Push Button - Non Illuminated

Momentary single pole stainless steel push button switch.

- 6 Amps @ 12v
- Screw terminals
- Mounts into 19mm diameter hole
- Nickel plated brass body

Dimensions: 25mm (w) x 32mm (d)



PART NO.	DESCRIPTION	VOLTAGE
16-1431	Momentary Stainless Steel Push Button Switch	12/24v

Dual Colour Momentary Cyclic Push Button

Momentary cyclic push button switch with red/blue LED illumination that changes with each press to display selected mode.

- Dual colour LED illumination when in use - unlit when off
- Brushed steel anti-vandal switch
- 22mm front bezel micro switch
- IP65 rated

Dimensions: 28.5mm (w) x 22.5mm (d)



PART NO.	DESCRIPTION	VOLTAGE
16-1429	Dual Colour Momentary Push Button Switch	12/24v

Round Momentary Push Button

Momentary ON dot illuminated single pole push button switch.

- 500mm flying lead terminals
- 16mm tactile panel mount push button
- Dot LED indicator
- Epoxy sealed

Dimensions: 20mm (ø) x 34mm (d)



PART NO.	DESCRIPTION	VOLTAGE
16-1030	Red Momentary Push Button with LED Indicator	12v
16-1031	Yellow Momentary Push Button with LED Indicator	12v
16-1032	Blue Momentary Push Button with LED Indicator	12v

Telescopic Plunger Switch

47mm long spring loaded plunger switch.

- 20 Amps @ 12v
- 29mm panel clearance
- Non-corroding copper terminals
- Self adjusts to door gap

Dimensions: 68.7mm overall length



PART NO.	DESCRIPTION	VOLTAGE
16-1094	Telescopic Door Plunger Switch	12v

Encapsulated Mercury Tilt Switch - Clear

Glass bodied mercury switch in a clear polystyrene housing.

- 4° vertical and 10° horizontal differential angle
- 500mA maximum carrying current
- Low contact resistance
- Hermetically sealed contacts

Dimensions: 30mm (l) x 20mm (d) x 7mm (h)

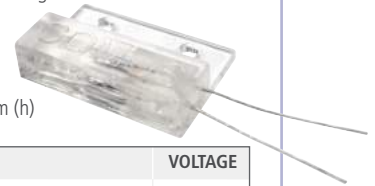

PART NO.	DESCRIPTION	VOLTAGE
16-1071	Encapsulated Tilt Switch	12v

Encapsulated Mercury Tilt Switch - Blue

Glass bodied mercury switch in a blue ABS housing.

- 10° differential angle
- 2 Amp maximum carrying current
- Pre-wired with 300mm 2 core flying lead
- Hermetically sealed contacts

Dimensions: 47mm (l) x 11mm (d) x 12mm (h)

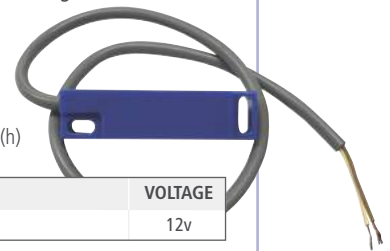







PART NO.	DESCRIPTION	VOLTAGE
16-1100	Encapsulated Tilt Switch	12v

Relays, Plugs and Sockets

PART NO.	DESCRIPTION
16-1051	 12V Micro Change Over Relay with Diode 15/25 amp sealed with diode. 3 x 4.8mm and 2 x 6.3mm terminals.
16-1052	 Bulkhead Socket for Micro Relays Accepts up to 2 x 2.8mm 3 x 4.8mm and 2 x 6.3mm terminals. Can be gang mounted.
16-1118	 12V Mini Change Over Relay with Bracket 12 volt, 20/30 amp with bracket. 5 x 6.3mm terminals.
16-1119	 24V Mini Change Over Relay with Bracket 24 volt, 10/20 amp with bracket. 5 x 6.3mm terminals.
22-1010	 Cigar Plug Connector - Universal 16 Amp with strain relief.
22-1055	 Cigar Plug Connector - Bendable 8 Amp with strain relief.
22-1054	 Socket Outlet Receives universal and bendable cigar plug connectors.
22-1052	 Din Socket Din socket with protective spring cap.
22-1053	 Socket Adaptor 8 Amp Din to cigar plug socket adaptor.
ACC-341	 Dual USB/Cigar Socket Power Adaptor 8 Amp, 12v waterproof USB and cigar socket power adaptor.

MCS Device Comparison Charts

MCS Control Units Comparison Chart

Generic Code	MCS-32	MCS-32-NS	MCS-32S	MCS-32S-NS	MCS-16	MCS-16-NS
Description	MCS-32 With Siren	MCS-32 Without Siren	MCS-32 SLAVE With Siren	MCS-32 SLAVE Without Siren	MCS-16 With Siren	MCS-16 Without Siren
						
Part Number	UNI-PLS-001	UNI-PLS-002	UNI-SLV-001	UNI-SLV-002	UNI-LIT-001	UNI-LIT-002
Function						
12 or 24 Volt	12/24 Volt	12/24 Volt	12/24 Volt	12/24 Volt	12/24 Volt	12/24 Volt
Siren	Yes	No	Yes*	No	Yes	No
Siren 'Test Mode' (12v only)	Yes	N/A	Yes	N/A	Yes	N/A
Siren 'City Mode' (12v only)	Yes	N/A	Yes	N/A	Yes	N/A
Low Battery 'Bleep'	Yes	N/A	No	N/A	Yes	N/A
PA Function	Yes	N/A	No	N/A	Yes	N/A
HRT Positive Input	Yes	Yes	Yes	Yes	Yes	Yes
HRT Negative Input	Yes	Yes	Yes	Yes	Yes	Yes
Intercom	Yes	Yes	No	No	Yes	Yes
Message Announcement	Yes	Yes	No	No	No	No
RS485/PWM (Handset)	Yes	Yes	No	No	Yes	Yes
Vehicle CAN Port	Yes	Yes	No	No	Yes	Yes
System CAN Port	Yes	Yes	Yes	Yes	Yes	Yes
Negative Inputs	12	12	12	12	8	8
Positive Inputs	12	12	12	12	8	8
Hi Current Outputs	16	16	16	16	8	8
Low/Medium Current Outputs	16	16	16	16	8	8
Monitor Outputs Med	0	0	0	0	0	0
Monitor Outputs Low	0	0	0	0	0	0
PA via Switch Unit	Yes	No	N/A	N/A	Yes	No
PA via Microphone	Yes	No	N/A	N/A	Yes	No

* The MCS-32 Slaves that have sirens are 'slaved' to the main MCS-32 Controller siren and as such have no independent control functions (HRT etc). Therefore they run tones in 'dual tone' mode with only alternating tones and cannot run tones in parallel.

MCS Devices Compatible Multi-Way Switch Units

Generic Code	MCS-32	MCS-32-NS	MCS-32S	MCS-32S-NS	MCS-16	MCS-16-NS
Switch Type						
T8 Mini Handset UNI-MIN-XXX	Yes	Yes	No	No	Yes	Yes
T10 Midi Handset UNI-MID-XXX	Yes	Yes	No	No	Yes	Yes
T16 MaxiPlus Handset UNI-MXH-XXX	Yes	Yes	No	No	Yes	Yes
T17 Handset Plus UNI-HAP-XXX	Yes	Yes	No	No	Yes	Yes
T17 Display Handset UNI-DIS-XXX	Yes	Yes	No	No	Yes	Yes
F5 Slimline Switch Unit UNI-SLM-XXX	Yes	Yes	No	No	Yes	Yes
F5D Slimline Switch Unit UNI-SLM-XXX	Yes	Yes	No	No	Yes	Yes
F5T Slimline Switch Unit UNI-SLM-XXX	Yes	Yes	No	No	Yes	Yes
F14 Maxi Switch Unit UNI-MAX-XXX	Yes	Yes	No	No	Yes	Yes
F16 MaxiPlus Switch Unit UNI-MXF-XXX	Yes	Yes	No	No	Yes	Yes
T8A Mini Switch Panel UNI-MIN-XXX	Yes	Yes	No	No	Yes	Yes
T16A MaxiPlus Switch Panel UNI-MXP-XXX	Yes	Yes	No	No	Yes	Yes
P12 MidiPlus Switch Panel UNI-MDP-XXX	Yes	Yes	No	No	Yes	Yes
P16 MaxiPlus Switch Unit UNI-MXP-XXX	Yes	Yes	No	No	Yes	Yes
TSC Touch Screen Controller UNI-TSC-XXX	Yes	Yes	No	No	Yes	Yes

MCS-8 MCS-8 With Siren	MCS-8-NS MCS-8 Without Siren	MCS-H16 MCS-H16 Without Siren	MCS-H16S MCS-H16 Slave Without Siren	MCS-SE MCS-SE 100w Siren	MCS-SSA MCS-SSA 100w Basic Siren	MCS-DDSA MCS-DDSA 200w Digital Siren	MCS-DSA MCS-DSA 60w Digital Siren
							
UNI-EIG-001	UNI-EIG-002	UNI-HPC-002	UNI-SLV-H16	UNI-SIR-001	PAA-167-03	UNI-SIR-D20	UNI-SIR-D60
12/24 Volt	12/24 Volt	12/24 Volt	12/24 Volt	12/24 Volt	12/24 Volt	12/24 Volt	12 Volt
Yes	No	No	No	Yes	Yes	Yes	Yes
Yes	N/A	N/A	N/A	Yes	Yes	Yes	Yes
Yes	N/A	N/A	N/A	Yes	Yes	Yes	Yes
Yes	N/A	N/A	N/A	Yes	Yes	Yes	Yes
Yes	N/A	N/A	N/A	Yes	No	No	No
Yes	Yes	Yes	Yes	Yes	Yes	Yes	Yes
Yes	Yes	Yes	Yes	Yes	Yes	Yes	Yes
Yes	Yes	Yes	No	No	No	No	No
No	No	No	No	No	No	No	No
Yes	Yes	Yes	No	No	No	No	No
Yes	Yes	Yes	No	No	No	No	No
Yes	Yes	Yes	Yes	Yes	Yes	Yes	Yes
Configurable	Configurable	No	No	3	1	2	2
Up to 10	Up to 10	7	7	3	1	5	5
Up to 4	Up to 4	16	16	0	0	3	0
Up to 4	Up to 4	0	0	3	0	3	3
0	0	0	0	0	0	0	0
0	0	0	0	0	0	1	1
Yes	No	No	N/A	No	No	No	No
Yes	No	No	N/A	Yes	No	Yes	Yes

MCS-8	MCS-8-NS	MCS-H16	MCS-H16S	MCS-SE	MCS-SSA	MCS-DDSA	MCS-DSA
Yes	Yes	Yes	No	Yes	Yes	Yes	Yes
Yes	Yes	Yes	No	Yes	Yes	Yes	Yes
Yes	Yes	Yes	No	No	No	No	No
Yes	Yes	Yes	No	No	No	No	No
Yes	Yes	Yes	No	No	No	No	No
Yes	Yes	Yes	No	Yes	Yes	Yes	Yes
Yes	Yes	Yes	No	No	No	No	No
Yes	Yes	Yes	No	No	No	No	No
Yes	Yes	Yes	No	No	No	No	No
Yes	Yes	Yes	No	Yes	Yes	Yes	Yes
Yes	Yes	Yes	No	No	No	No	No
Yes	Yes	Yes	No	No	No	No	No
Yes	Yes	Yes	No	No	No	No	No
Yes	Yes	Yes	No	No	No	No	No
Yes	Yes	Yes	No	No	No	No	Yes

Typical System Specifications

Single handset with optional built-in microphone

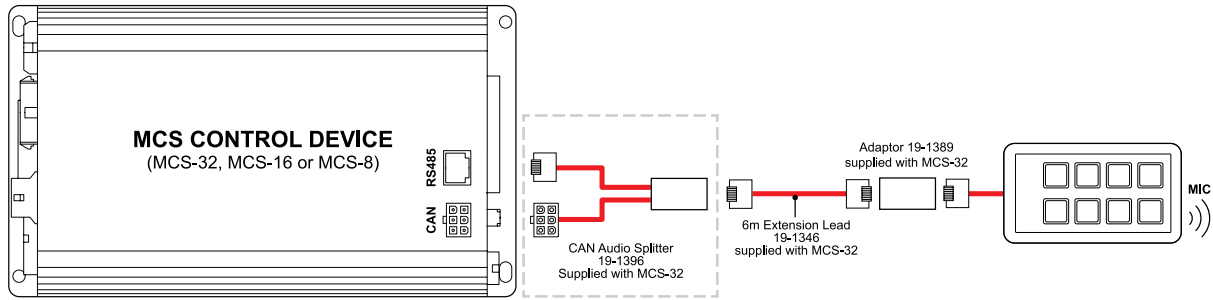

Single handset with PA microphone

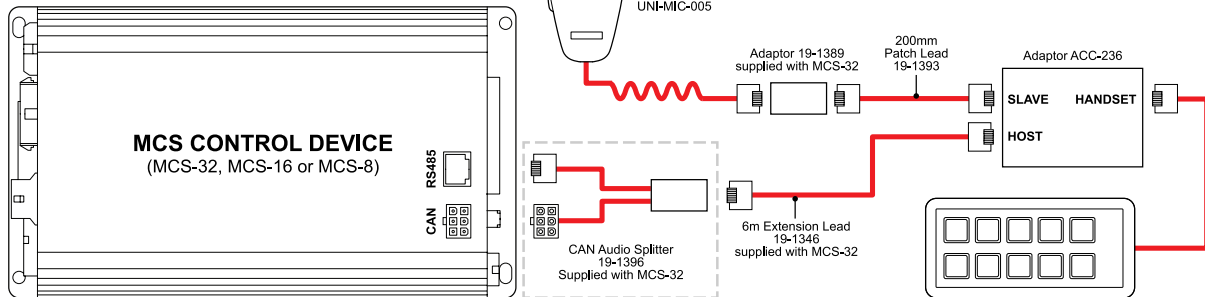

Two handsets not exceeding 20 buttons in total

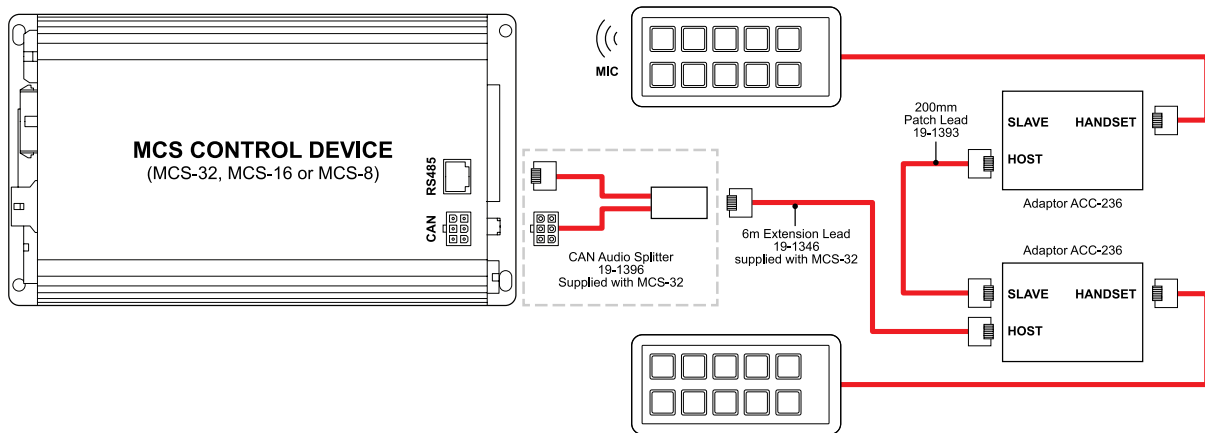

For applications requiring between two and four handsets

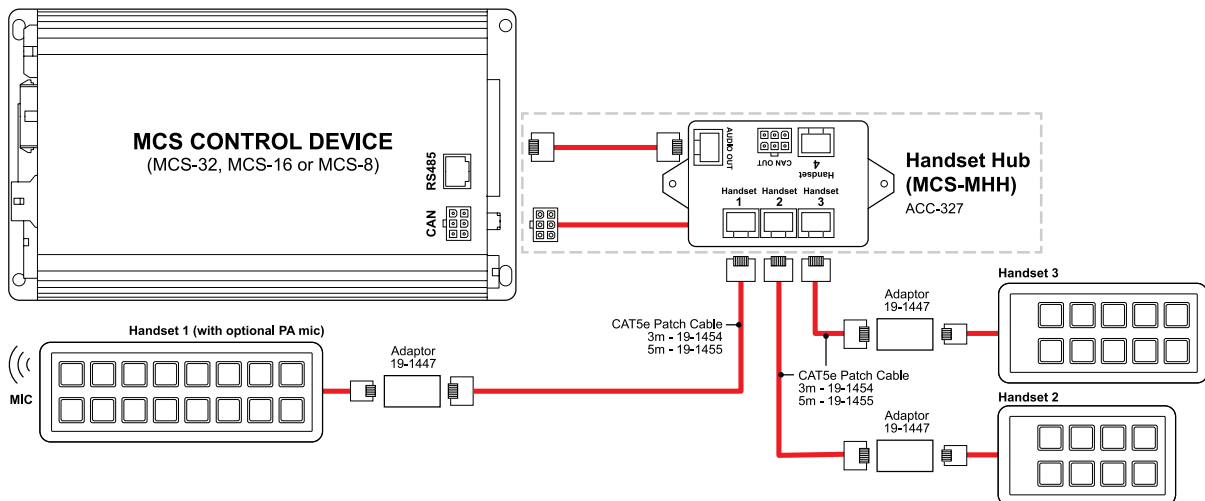

For applications requiring between two and four handsets and additional outputs via a Universal Load Switch

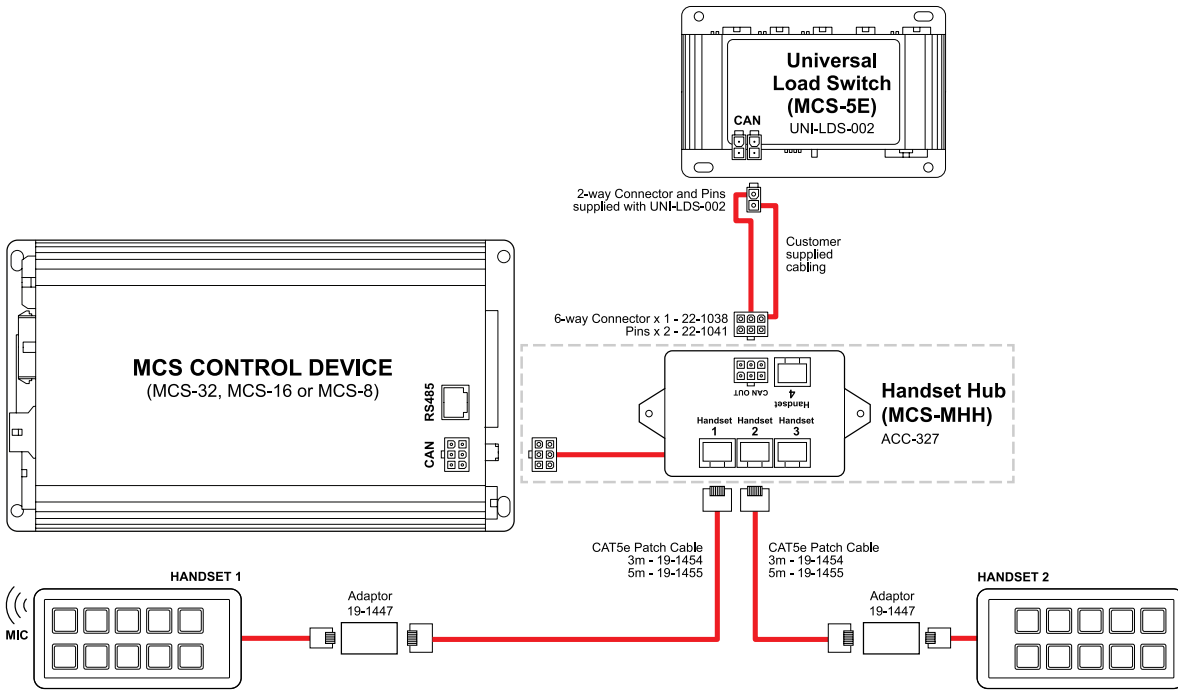

Three handsets, 64 outputs with voice warnings and two-way intercom - typically A&E Box Ambulance

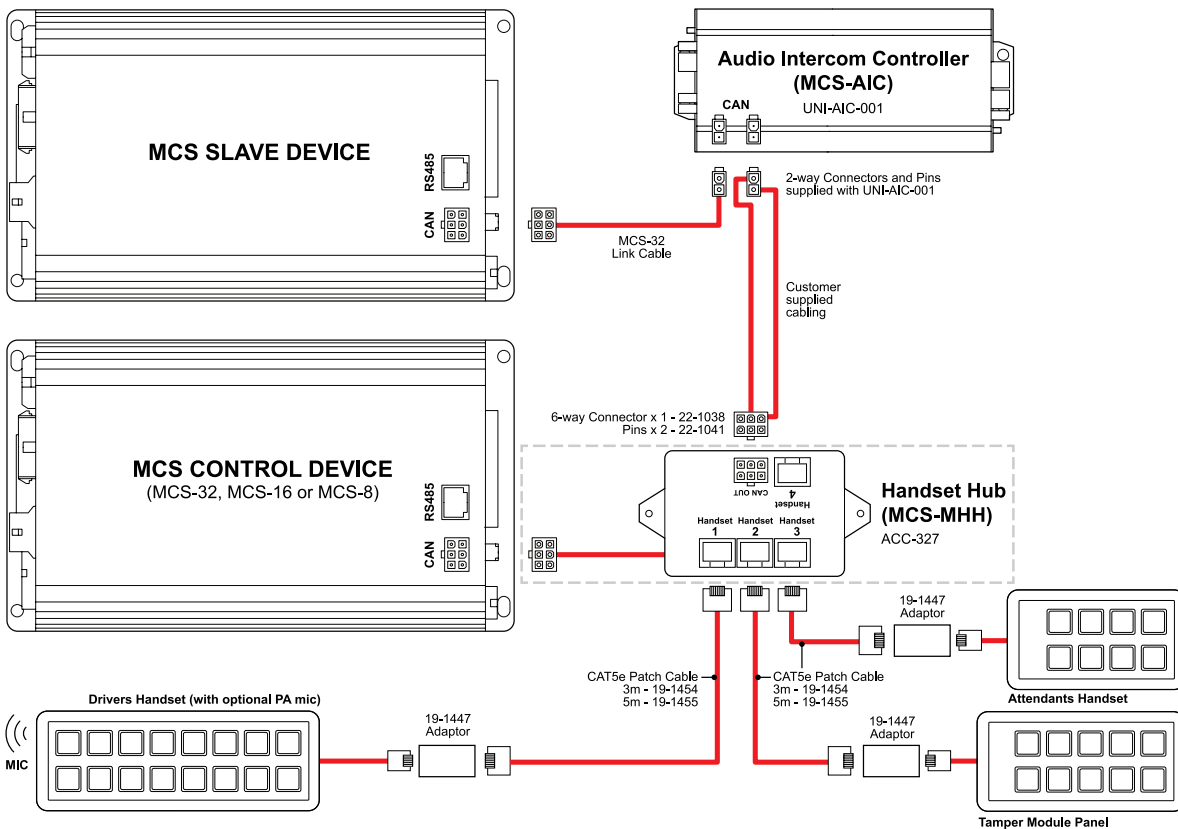

MCS Devices Connectors, Adaptors and Cables

MCS Devices Connector Kits

MCS Device	Description	Connector Kit	Part Number
MCS-32	Control Unit	Full Connector Set	22-1508
		Pins and Plugs Only	22-1507
MCS-32S	Slave Unit	Full Connector Set	22-1508
		Pins and Plugs Only	22-1507
MCS-16	Control Unit	Full Connector Set	22-1700
		Pins and Plugs Only	22-1584
MCS-8	Control Unit	Full Connector Set	22-1701
		Pins and Plugs Only	22-1598
MCS-H16	Control Unit	Full Connector Set	22-1702
MCS-6E	Control Unit	Full Connector Set	22-1703
		Pins and Plugs Only	22-1572
MCS-5E	Universal Load Switch	Full Connector Set	22-1704
MCS-LBC10	Lighting Breakout Controller	Full Connector Set	22-1705
MCS-LBC20	Lighting Breakout Controller	Pins and Plugs	22-1706
MCS-CIM	CAN Interface Module	Pins and Plugs	22-1707
MCS-DDSA	200W Digital Siren	Pins and Plugs	22-1708
MCS-DSA	60W Digital Siren	Pins and Plugs	22-1709
MCS-SE	100W Siren	Pins and Plugs	22-1668
MCS-SSA	100W Siren	Pins and Plugs	22-1668
MCS-AIC	Audio Intercom Controller	Pins and Plugs	22-1710

Connectors and Pins compatible with MCS Devices

MCS-32 (UNI-PLS-001), **MCS-32S** (UNI-SLV-002), **MCS-16** (UNI-LIT-001) and **MCS-8** (UNI-EIG-001)

Connector Kit	Description	Standby RSG Part Number	Farnell Part Number	Quantity	
				MCS-32	MCS-32S
Complete Connector Set	Full Set	22-1508	N/A	1	1
Part Connector Set Item Code 2011277	Pins and Plugs Only	22-1507	N/A	1	1
High Power Outputs	15-way Housing	22-1407	285-213	1	1
	Crimp Socket	22-1422	285-407	15	15
Siren Speaker	4-way Housing	22-1409	3422549	1	1
	Crimp Pin	22-1423	285-389	2	15
Aux Connector	9-way Housing	22-1514	143-211	1	-
	Crimp Pin	22-1515	9773800	9	-
Power	4-way Housing	22-1516	307-5801	1	1
	10 AWG Crimp Socket	22-1449	973-3132	4	4
Low Power Outputs	16-way Connector	22-1411	157-8475	1	1
	22-18 AWG Crimp Socket	22-1421	81-6067	16	16
System	2-way Housing	22-1046	151-866	1	2
	22-18 AWG Crimp Socket	22-1421	811-6067	2	2
CAN Bus Cable	CAN Audio Splitter	19-1396	N/A	1	1
Inputs	24-way Housing	22-1495	413-8417	1	1
	22-18 AWG Crimp Socket	22-1421	811-6067	24	24
Audio	4-way Housing	22-1037	151-867	1	-
	22-18 AWG Crimp Socket	22-1421	811-6067	4	-

Connectors and Pins compatible with MCS-5E Load Switch

MCS-5E Load Switch UNI-LDS-002				
Connector Kit - MCS-032	Description	Standby RSG Part Number	Farnell Part Number	Quantity
CAN	2-way Housing	22-1046	151-866	2
	22-18 AWG Crimp Socket	22-1421	811-6067	4
Power	2-way Housing	22-1448	307-5783	1
	10 AWG Crimp Socket	22-1449	973-3132	2
Outputs 1 and 5	6-way Housing	22-1038	151-868	2
	22-18 AWG Crimp Socket	22-1421	811-6067	12
Outputs 2, 3 and 4	4-way Housing	22-1037	151-867	3
	22-18 AWG Crimp Socket	22-1421	811-6067	12

Connectors and Pins compatible with MCS-LBC10 Lighting Breakout Controller

MCS-LBC10 Lighting Breakout Controller UNI-LBC-001				
Connector Kit - MCS-032	Description	Standby RSG Part Number	Farnell Part Number	Quantity
CAN	6-way Housing	22-1038	151-868	1
	22-18 AWG Crimp Socket	22-1421	811-6067	6
Inputs/Outputs	24-way Housing	22-1495	413-8417	1
	22-18 AWG Crimp Socket	22-1421	811-6067	24

Connectors and Pins compatible with MCS-SE 100w Siren

Universal 100w Siren (MCS-SE) UNI-SIR-001				
Connector Kit - MCS-032	Description	Standby RSG Part Number	Farnell Part Number	Quantity
Inputs/Outputs	20-way Housing	22-1410	811-6202	1
	22-18 AWG Crimp Socket	22-1421	811-6067	20
Power Connector	2-way Housing	22-1448	307-5783	1
	10 AWG Crimp Socket	22-1449	973-3132	2

Connectors and Pins compatible with MCS-SSA Basic 100w Siren

Basic Stand-alone 100w Siren (MCS-SSA) PAA-167-03				
Connector Kit - MCS-032	Description	Standby RSG Part Number	Farnell Part Number	Quantity
Inputs/Outputs	20-way Housing	22-1410	811-6202	1
	22-18 AWG Crimp Socket	22-1421	811-6067	20
Power Connector	2-way Housing	22-1448	307-5783	1
	10 AWG Crimp Socket	22-1449	973-3132	2

Connectors and Pins compatible with MCS-AIC Audio Intercom Controller

MCS-AIC Audio Intercom Controller UNI-AIC-001				
Connector Kit - MCS-032	Description	Standby RSG Part Number	Farnell Part Number	Quantity
CAN	2-way Housing	22-1046	151-866	2
	22-18 AWG Crimp Socket	22-1421	811-6067	4
Inputs/Outputs	6-way Housing	22-1038	151-868	1
	22-18 AWG Crimp Socket	22-1421	811-6067	6
Speaker	2-way Housing	22-1046	151-866	2
	22-18 AWG Crimp Socket	22-1421	811-6067	4
Microphone	4-way Housing	22-1037	151-867	2
	22-18 AWG Crimp Socket	22-1421	811-6067	8

Universal Devices Connectors, Adaptors and Cables continued

Programming Items for use with MCS Devices

MCS-32 Device and Part Number	Item Description	Item Part Number	Quantity
MCS-32 Control Unit - UNI-PLS-001 and MCS-32S Slave Unit UNI-SLV-001	Programming CD Only	UNI-PRO-002	1
	Programming Lead Only	ACC-237	1
	Programming Lead and CD	ACC-256	1
MCS-16 Control Unit - UNI-LIT-001	Programming CD Only	UNI-PRO-002	1
	Programming Lead Only	ACC-237	1
	Programming Lead and CD	ACC-256	1
MCS-8 Control Unit - UNI-EIG-001	Programming CD Only	UNI-PRO-002	1
	Programming Lead Only	ACC-237	1
	Programming Lead and CD	ACC-256	1
MCS-H16 Control Unit - UNI-HPC-002	Programming CD Only	UNI-PRO-002	1
	Programming Lead Only	ACC-237	1
	Programming Lead and CD	ACC-256	1
MCS-CANIO Can Bus Interface Module - UNI-CAN-001	Programming CD Only	UNI-PRO-003	1
	Programming Cable	UNI-CAN-003	1
	Programming Lead and CD	KIT-259	1
MCS-SE 100w Siren - UNI-SIR-001	Programming Cable	ACC-247	1
MCS-SSA Basic 100w Siren - PAA-167-03	Programming Cable	ACC-247	1
MCS-AIC Audio Intercom Controller - UNI-AIC-001	Programming CD Only	UNI-PRO-002	1
	Programming Lead Only	ACC-237	1
	Programming Lead and CD	ACC-256	1
USB Programming Cable for MCS Devices with USB connection	Mini USB Programming Cable	ACC-247	1

Note: All items are only issued to suitably trained and authorised resellers

Microphones for use with MCS Devices

General Description and Application	Item Code	Part Number
MCS-32 Microphone with pre-amp (compatible with legacy DIN adaptor) UNI-INT-001	2011274	UNI-MIC-005
Panel Mount Microphone Kit - for use with MCS-AIC	-	UNI-MIC-007
Panel Mount Microphone Kit - including 2m cable - for use with MCS devices	-	KIT-247
Panel Mount Microphone Kit - including 6m cable - for use with MCS devices	-	KIT-257
Microphone clip for T17 Handset - metal both halves	2011001	UNI-MIC-006
Microphone mounting kit - dash half - spare	Clip Bracket	13-1250
Microphone mounting clip for - plastic - both halves (all handsets except T17) - spare	2011287	ACC-242

Adaptors for use with MCS-32 Devices

General Description and Application	Item Code	Part Number
MCS-32 Adaptor - Use with 2 x Switch Units or 1 x Microphone and 1 x Switch Unit	2011269	ACC-236
MCS-32 CAN Fan Out Adaptor - RJ Socket to 6-way Molex	2011048	ACC-282
MCS-32 CAN Adaptor - RJ Socket to 6-way Male to 6-way Female Molex	2013007	ACC-284
MCS-32 CAN 'T' Adaptor - MCS-5E 2-way to 6-way Female Molex	2013003	ACC-278
Adaptor for CAN Handsets + MCS-32/MCS-SE + Microphone	2011040	19-1389
CAN/Audio Splitter (supplied with MCS-32)	2011257	19-1396
Hub - Handset Adaptor	2015002	19-1447
CAN Handset/Microphone/RS485 Splitter Adaptor	2013051	ACC-309
MCS-32 Adaptor - Accepts Micro-Link Handset, Fist Microphone, PWM	2015074-ULINK	UNI-INT-003
MCS-32 Adaptor - Accepts Opti-Link, Opti-Din, Microphone, PWM	2015074	UNI-INT-002

Cables for use with MCS-32 Devices

General Description and Application	Item Code	Part Number
0.2m Cross Over Cable use with ACC-236 Adaptor	N/A	19-1393
1.5m Cross Over Cable General System Extension	N/A	19-1388
2m Cross Over Cable Microphone or Switch Unit Extension for MCS-32	2011039	19-1394
6m Cross Over Cable as supplied with MCS-32	2011017	19-1346
10m Cross Over Cable as supplied with MCS-32	2011017	19-1346

Sundry items for use with MCS-32 Devices

General Description and Application	Item Code	Part Number
Molex Crimp Tool 16 to 24 AWG	N/A	45-1005
Extraction Tool for Molex Crimp Terminals	N/A	45-1006
T10 Midi Handset - Rubber Surround - Spare	2011232-QFT	ACC-316
T10 Midi Handset - Quick Fit Rubber Shroud - Spare	2011232-SHD	ACC-325
T16 MaxiPlus Handset - Rubber Sun Shield - Spare	N/A	ACC-346
F5 Slimline Switch Unit - Rubber Shroud - Spare	N/A	ACC-356

Sundry items for use with Auto Recall - AUT-500

General Description and Application	Item Code	Part Number
Full Connector Set	N/A	22-1711

MCS-32 Hub Devices



















General Description and Application	Part Number
Handset Hub Adaptor	19-1447
3m CAT 5e Cable	19-1454
5m CAT 5e Cable	19-1455
10m CAT 5e Cable	AEX-C-CAB-B10M

BMW Specific Items for use with MCS-32 Devices

General Description and Application	Part Number
BMW Complete Interface Loom for MCS-32 with instructions, Resistor Pack and Adaptor	KIT-156
BMW Interface Loom Only - Spare	19-1432
BMW Resistor Pack for Interface Loom	22-1558
Siren Reduction (from 100 to 60 Watts) Transformer for all MCS Sirens	ACC-308

Typical Vehicle Application Chart

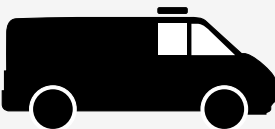
The MCS family of control units and expansion units was specifically developed to work together to provide a complete hazard warning lighting and equipment system across a wide range of vehicle types.

Device	Typical Vehicle Type	Typical Blue Application	Typical Amber Application
MCS UNO Systems 		<ul style="list-style-type: none"> Covert Police Car Fire Officer Car Dog Van 	<ul style="list-style-type: none"> Basic Tow Truck Highway Maintenance Diggers
MCS Mini/Midi Systems 		<ul style="list-style-type: none"> Economic Police Car 	<ul style="list-style-type: none"> Full Recovery Truck
MCS Midi/Maxi Systems 		<ul style="list-style-type: none"> Low Spec General Purpose Police Car 	<ul style="list-style-type: none"> Wide Load Vehicle
MCS-8 Control Unit 		<ul style="list-style-type: none"> Framework General Purpose Police Car 	<ul style="list-style-type: none"> Recovery Truck with Lights Auto Ramps and Winch
MCS-16 Control Unit 		<ul style="list-style-type: none"> Framework General Purpose Police Car Ambulance RRV Fire Service Responder 	<ul style="list-style-type: none"> Recovery Truck with Lights Auto Ramps and Winch Agricultural Vehicles
MCS-32 Control Unit 		<ul style="list-style-type: none"> Fast Response Car Ambulance RRV Fire Service Responder Fire Appliance 	<ul style="list-style-type: none"> Race Pace Car Agricultural Vehicles Coach and Bus Refuse Collection Earth Movers
MCS-32 Control Unit & MCS-32S Slave Unit 		<ul style="list-style-type: none"> Box/Van Body Ambulance 	<ul style="list-style-type: none"> Complex Plant Vehicles
MCS-H16 Control Unit 		<ul style="list-style-type: none"> Box/Van Body Ambulance Prison Van Dog Van 	<ul style="list-style-type: none"> Refuse Collection Complex Plant Vehicles
MCS-AIC Audio Intercom Controller 		<ul style="list-style-type: none"> Box/Van Body Ambulance Prison Van Mini Bus 	<ul style="list-style-type: none"> Coach and Bus Refuse Collection
MCS-5E Load Switch 		<ul style="list-style-type: none"> Bus and Coach Mini Bus 	<ul style="list-style-type: none"> Mini Bus

Highways Agency

Land Rover Discovery

- MCS-32 Control Unit
- T16 Handset
- Stellar LED Lightbar
- Xtreme 12-way LED Module
- Micromax Xtreme Dash Light



Traffic Commander Programmable LED Matrix Display

Large bright character format allows messages to be seen at a safe distance by moving vehicles

The NEW Traffic Commander LED Matrix Display has two distinct versions available. The first is a flip down/up device that is simply programmed and rotated to suit its location and is ideal for covert use with the second being a fixed unit.

The LED text panel consists of 288 next generation Amber LEDs with 6 character static capacity and scrolling function for longer messages.

The kit includes free message editing software and a hand held controller with easy to use function buttons and rubber surround.

- Over 2000 characters/100 words can be stored
- Available flip down, flip up and fixed
- Message editing software - programme your own choice of messages
- Large display controller with rubber surround
- Unique preview feature for easy message selection
- Open/close protection control
- Dimming feature - side light connection 50% as standard
- Corrosion resistant aluminium and stainless steel construction
- 12/24v operation
- 12 month warranty



TRAFFIC COMMANDER - KITS	
PART NO.	DESCRIPTION
MES-KIT-D6C	Flip Down/Up Traffic Commander Display controller, 5m extension and adaptor
MES-KIT-F6C	Fixed Traffic Commander Display controller, 5m extension and adaptor
MES-KIT-MDTD	Flip Down/Up Traffic Commander RS232 harness and adaptor
MES-KIT-MDTF	Fixed Traffic Commander RS232 harness and adaptor

TRAFFIC COMMANDER - REPLACEMENT PARTS	
PART NO.	DESCRIPTION
MES-D6CA	Flip Down/Up Traffic Commander Display Unit
MES-F6CA	Fixed Traffic Commander Display Unit
MES-MCS-G4-L	Display Controller with Surround (111x56x19mm)
19-1412	5m Extension Cable (RJ12)
19-1389	Adaptor (Female RJ-RJ)
ACC-370	USB-A Data Cable (A male to USB)
19-1517	RS232 Adaptor for mobile data terminals (MDT)

8:72

Section 8 : Feature Products

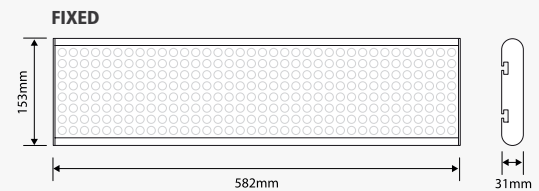
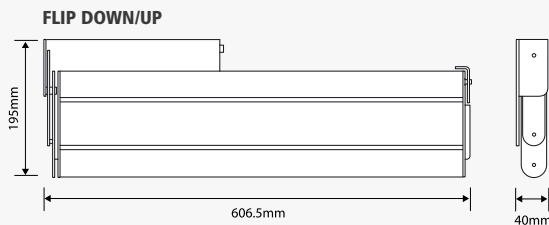

Trail Blazer 2

Portable mini lightbar with integral siren

The Trail Blazer 2 is a fully integrated, ergonomic unit that is lightweight and easy to install/remove. Incorporating state-of-the-art LED's, digital siren technology and strong magnets as well as being fully type approved to ECE R10 and DEKRA speed tested to 124 mph (200kph).

Siren Speaker

The integral multi-tone digital siren has a power rating of 60 Watts, but has a dB sound rating equivalent to 80 Watts (typically 106.3 dB @ 7 metres). Three siren tones - Yelp, Wail, Hi/Lo and Air Horn - are projected through an unobtrusive, low profile speaker positioned on the underside of the lightbar.

LED Light Heads

Super bright LED's including a Gatso module are set to the rear, front and corners of the lightbar creating full 360° light output.

There are currently 2 models available, the Standard edition has all blue LED's including a Gatso to the rear with a blue lens, the Advanced edition includes front take downs and rear reds as well as a Gatso with a clear lens.

Multi-Functional Switch Panel

The 5-way (standard) and 7-way (advanced) switch panels offer reliable direct control of the lighting and siren features.

The illuminated handsets have multi-functional pre-programmed Start/Stop/Siren scrolling tone and 999 buttons, just like you would expect to find in a fully marked emergency services vehicle with functions including:

- 999 Button to immediately start Blue Lights and Siren
- Individual buttons to turn each function On and Off
- Single multi-purpose Siren control button for all tone functions
- Buttons are dimly lit when the function is off and brightly lit when the function is on

Standard Features:

- 60W digital siren with a dB sound rating equivalent to 80 Watts (typically 109.9 dB @ 7 metres)
- 3 scrolled siren tones; Yelp, Wail, Hi/Lo and Air Horn
- 1 built-in flash pattern - Double 2Hz Left/Right split
- Supplied with illuminated handset controller; Standard - 5 buttons, Advanced - 7 buttons
- Pre-programmed Start/Stop/Siren and 999 buttons
- Illuminated buttons set at 50% brightness when idle, 100% brightness on activation
- 5 metre low profile power cable
- Strong magnets DEKRA speed tested to 124mph (200kph)
- Magnets are attached via self leveling gimbals
- Available with UV stable coloured lenses (standard version) or clear lenses (advanced version)
- Integral moulded speaker to the underside
- Supplied with adjustable lanyard and heavy duty carry bag
- 12v operation
- Approximately 5.8 kilograms
- 3 year warranty on lightbar only, integrated siren has a 12 month warranty
- ECE R10 (e) approved
- Dimensions: 450mm wide x 205mm deep x 112mm high

TRAIL BLAZER 2	
PART NO.	DESCRIPTION
TB2-TB18B-22M11	Trail Blazer 2 - Standard Version
TB2-TB18B-22M21	Trail Blazer 2 - Advanced Version

TRAIL BLAZER 2 (Standard Edition)

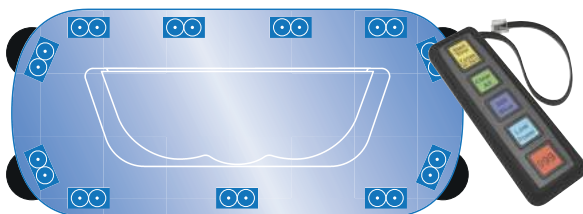

TRAIL BLAZER 2+ (Advanced Edition)

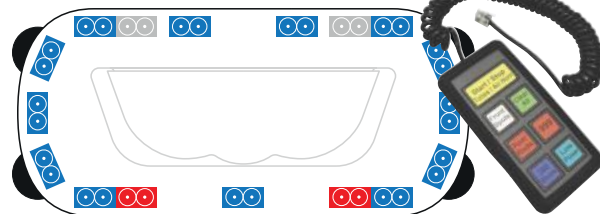

Other colour and mounting options are in development and will be available soon!



Hurricane LED Lightbar

Be safe, be legal and be seen at an affordable price. Both ECE R65 Class 1 and ECE R10 (e) approved!

The Hurricane LED Lightbar is a cost effective, slimline unit with high quality, UV stabilised polycarbonate lenses in both clear and new transient blue.

Transient blue lenses allow white and red light to shine through without being affected by its colour whilst also maintaining ECE R65 class 1 status.

This lightbar features latest generation 3-way LED modules as well as optional 3-way side alley, take down and Gatso modules.

Available 42" (1067mm) as standard the Hurricane is pre-loaded with Quad 2Hz Left/Right flash pattern and supplied with rubber mounting feet.

Below is a standard range of 42" lightbars, however we are able to engineer a Hurricane lightbar to your own personal requirements with a choice of lengths, LED modules and lens colours available. Please contact our dedicated sales team for further information.

Standard Features:

- Available with a crystal clear or transient blue UV stable polycarbonate lens. Amber versions also available to order
- 42" (1067mm) as standard, longer lengths available to order
- Supplied with standard rubber mounting feet
- 3.5m loom
- 3-way corner LED modules
- 3-way front and rear facing LED modules
- Standard Quad 2Hz Left/Right flash pattern, other flash patterns available to order
- IP56 dust and water resistant
- ECE R65 Class 1 and ECE R10 (e) approved
- 12/24v operation
- 6.68A current @ 12v
- 3 year manufacturers warranty
- Dimensions: 1067mm wide x 215mm deep x 65mm high

Optional Features:

- 3-way LED alley lights
- 3-way LED takedowns
- 3-way LED GATSO (steady burn) module
- CAN Bus option
- Amber version

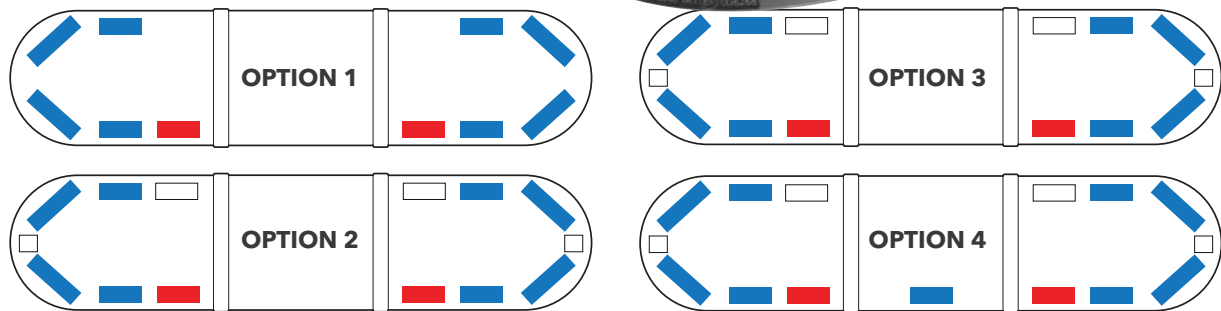

HURRICANE LED LIGHTBAR		
DESCRIPTION	LENS	PART NUMBER
42" Hurricane LED Lightbar - Option 1 Front: 2 x Blue 3-way Rear: 2 x Blue 3-way Ends: 2 x Blue 3-way	Blue Clear	HUR-TB42B-33543 HUR-TB42C-33543
42" Hurricane LED Lightbar - Option 2 Front: 2 x Blue 3-way Rear: 2 x Blue 3-way, 2 x Red 3-way Ends: 2 x Blue 3-way, 1 x 3-way Alley Light	Blue Clear	HUR-TB42B-33243 HUR-TB42C-33243
42" Hurricane LED Lightbar - Option 3 Front: 2 x Blue 3-way, 2 x 3-way Takedowns Rear: 2 x Blue 3-way, 2 x Red 3-way Ends: 2 x Blue 3-way, 1 x 3-way Alley Light	Blue Clear	HUR-TB42B-33063 HUR-TB42C-33063
42" Hurricane LED Lightbar - Option 4 Front: 2 x Blue 3-way, 2 x 3-way Takedowns Rear: 2 x Blue 3-way, 2 x Red 3-way, 1 x Blue Gatso Ends: 2 x Blue 3-way, 1 x 3-way Alley Light	Blue Clear	HUR-TB42B-33563 HUR-TB42C-33563

Silverblade LED Lightbar

New sleek, ultra low profile premium LED lightbar for rapid response and armed law enforcement vehicles

At only 43mm high the Silverblade is one of the lowest profile premium LED lightbars available. Pack with 18, 9, 6 or 3-way latest generation LED light heads to build a lightbar that meets your exact performance needs and budget requirement.

It's streamlined design with crystal clear polycarbonate lenses that have just one single join at the centre make the Silverblade a durable, attractive and uncluttered choice.

The Silverblade is available with single and dual colour LED modules and optional LED alley lights and takedowns.

Available in 44" (1112mm), 48" (1235mm) and 54" (1358mm) lengths as standard the Silverblade has 12 built-in flash patterns and 3 flash modes.

We have a standard range of Silverblade lightbars however we are able to engineer a Silverblade to your personal requirements. Contact our dedicated sales team for more information.

Standard Features:

- UV stable polycarbonate lenses
- Supplied with low profile aluminium mounting brackets with integral protective rubber feet
- 4.8m loom
- 9-way single colour or 18-way dual colour corner LED modules
- 3-way or 6-way single colour and 6-way or 12-way dual colour front and rear facing LED modules
- LED modules available single or dual colour in blue, amber, red white, and green.
- 12 built-in flash patterns and 3 flash modes
- Built-in traffic director
- ECE R65 Class 2 and ECE R10 (e) approved
- 12v operation
- 5 year manufacturers warranty
- Dimensions: 294mm deep x 43mm high x chosen length

Optional Features:

- 3-way LED alley lights
 - 3-way LED takedowns
 - LED GATSO (steady burn) module



8:75

Typical Lightbar Specification

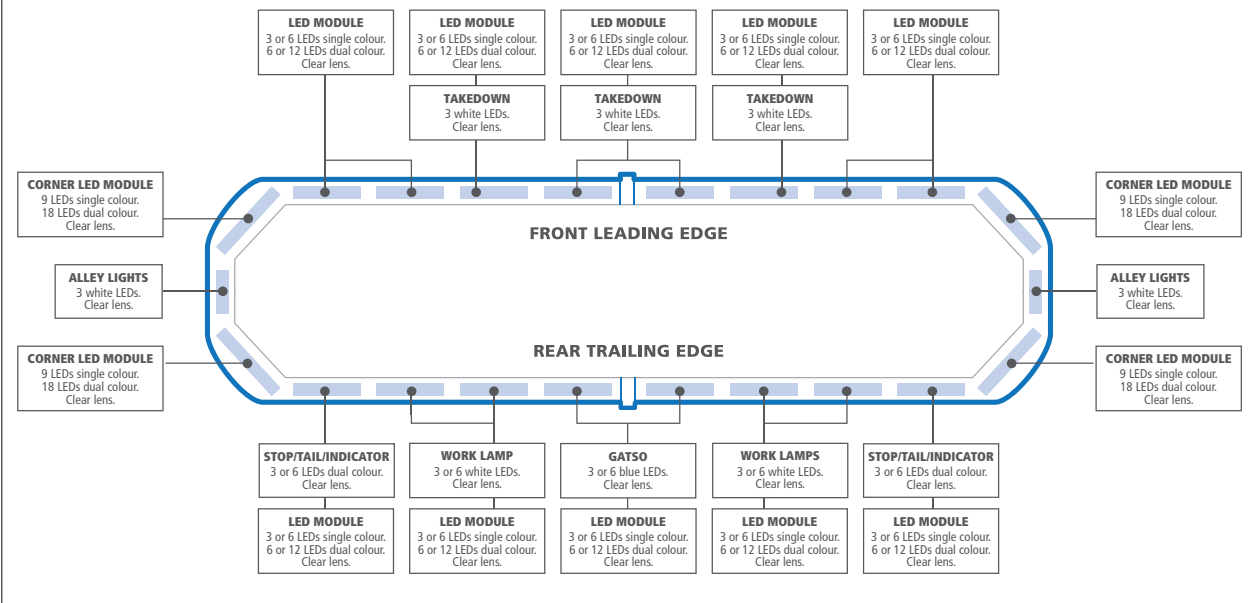

Section 8 : Feature Products

SDA100W Multi-functional 100W Siren, PA & Voice Recording (Auto Recall Type) Amplifier

A multiple purpose Amplifier that incorporates Emergency Services Siren Tones, a Public Address (PA) facility as well as a Voice Recording and Replay function

PRODUCT OVERVIEW

The SDA100W has the unique Mix Tone function that provides a dual tone effect from a single speaker. It also incorporates a 'Record-n-Play' voice function for repeating PA messages.

SDA100W functions and features:

- 100W siren amplifier optimised for use with JS100-C1 11 Ohm speaker (see below)
- Class D amplifier for low amp draw, clean tone and compact design
- Siren interlock input that disables siren activation without primary warning
- 15 selectable tone group to meet various European countrys standards
- Radio re-broadcasting (RRB) for audio replay
- Unique Mix-Tone function provides dual speaker effect with a single speaker
- Optional microphone and PA function with hand held mic
- 'Record-n-Play' record your voice and play back instantly without the need for a memory card - volume pre-set when recording is made
- Reverse polarity protection
- Full product operating information available on request

Specifications:

- 12/24v operation
- 100 Watts siren output
- 759Hz - 1592Hz siren frequency
- 9A @ 12VDC / 4.5A @ 24VDC
- 0 mA (without ignition wire) / <0.2A (with ignition wire)
- -20°C to 50°C operating temperature
- 5 year warranty

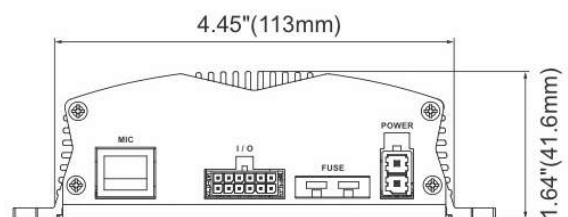
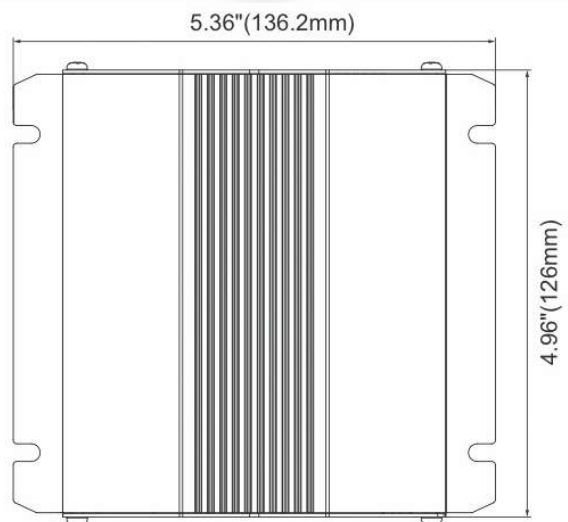

Note: Not compatible with CAN Bus devices or connection to vehicle CAN Bus

SDA100W 100W DIGITAL SIREN	
PART NO.	DESCRIPTION
PAA-100-03	SDA100W Digital Siren Amplifier
PAA-110-03	SDA100W Digital Siren Amplifier + Hand Held Mic
LSP-111	JS100-C1 100W, 11 Ohm Compact Speaker
ACC-455	JS100-C1 Compact Speaker L-Bracket
ACC-456	JS100-C1 Compact Speaker U-Bracket

JS100-C1 100W 11 Ohm Compact Speaker

A high performance 100W siren speaker with a powerful Neodymium internal magnet that produces more than 124.5dB over 3 metres.

- Reinforced Nylon housing with cast aluminium driver unit
- Industrial standard L-Bracket or U-Bracket (sold separately)
- 11 Ohms impedance
- 4.3 Ohms DC resistance
- Ferro Fluid cooling method
- -30°C - 65°C operating temperature
- -40°C - 75°C storage temperature
- Ingress protected to IP54K
- 124.5 dBA @ 3m (9.84') sound output

Overall dimensions: 75mm (d) x 161mm (w) x 161mm (h)



Note: Sold without mounting brackets - order separately

eCAN Contactless CAN Adapter DLH-435

Reads CAN data in a contactless mode without violating vehicle manufacturers warranty

The eCAN contactless reader allows the MCS to read vehicle CAN Bus data without the need to make a physical connection to the vehicles CAN wiring.

- CAN-BUS speed up to 1000 kb/s
- <1.2 mA (standby), <6.9 mA (working) at 12V
- -25°C to +85°C operating temperature range
- Compatible with the MCS-32, MCS-16, MCS-8 and the MCS-CANIO
- 10 - 30 V DC



SL157 Series LED Scene Lights

Sleek compact design with over 1400 lumen output and excellent light spread

PRODUCT OVERVIEW

The 45° angle design of the compact SL157 LED scene light delivers optimal light distribution and an exceptional light spread.

It's die cast aluminium base offers efficient heat dissipation and high LED durability.

Weatherproof and vibration resistant this model is suitable for internal and external use on both emergency and commercial vehicles.

- Simple compact design
- 4 high power LEDs
- 1400 lumen output
- Flood beam
- Reverse polarity protection
- Die cast aluminium base
- 12/24v operation
- Ingress protected to IPX7
- ECE R10 (e) approved
- 5 year manufacturers warranty

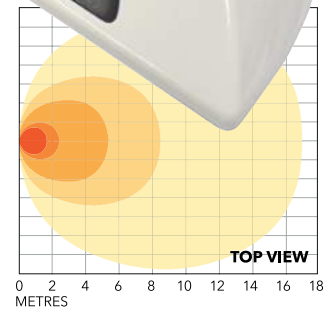
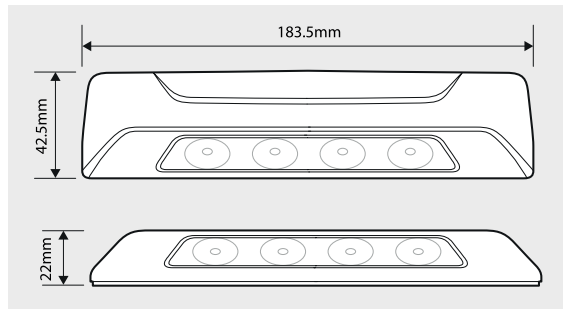

Magnetic Handset Holder ACC-453

Super strong magnetic base plate replaces conventional handset hang-up clip

The Magnetic Handset/Mic Holder enhances safety by reducing driver distraction.

The sheer strength of integrated magnetic plate means that you only have to hold the handset near to the plate and it will 'grab' it and securely hold it in position. You don't even need to take your eyes off the road!

Simply attach the base plate to the dash. A handset hanging clip is not required as our range of handsets have a full length steel plate in the rear meaning they have a large surface area for the magnet to latch on to.

- Enhances driver safety
- Replaces conventional dash mounted hang-up clips
- Easy to install, easy to use
- Durable construction
- Super strong magnet
- Supplied with adaptor for use with fist microphones (not for use with handsets)



8:77

Section 8 : Feature Products

FleetMotus

Vehicle Utilisation and Driver Behaviour Monitoring Tool

FleetMotus Telematics and Incident Analysis Solutions

Designed to monitor and manage large fleets of vehicles to individual drivers. Streamlining deployment, reducing accidental damage and encouraging appropriate driving methods.

- Real time monitoring and management
- User friendly customised reports
- Improves efficiency, saves money



autoeyeXpert

Mobile CCTV and Body-worn HD Video Recording Systems

AutoEye Xpert Transport Video Interface (TVI) & Internet Protocol (IP) CCTV Solutions

Professional grade mobile CCTV and video equipment to capture and record high definition video footage for security & safety, and surveillance & law enforcement evidence.

The first class HD imagery leaves no doubt about events of interest.

- Solutions to suit any specification or budget
- Provides indisputable visual evidence
- Use as a local or networked system solution



Do you know your LUX from your LUMEN?

LED lighting technology is without doubt the choice for the vast majority of companies. With so many manufacturers offering what appear to be similar products at widely differing prices, it's the light output performance that is the first thing used to make comparison. So do you know your LUX from your LUMEN?

LUX

Lux levels are determined using a Lux meter and is the measurement of the exact intensity of light at a given point away from the light unit. The Lux level will be influenced by the distance from the light source but also by a wide range of different factors including the product design, secondary lensing and the environment the light is fitted within.

LUMEN

Lumen is the unit of measurement for the light emitted from the source of a product, in this case an LED, and is reported using the abbreviation of 'lm'. Lumens can be a useful measure of anticipated light intensity, it should not be solely relied upon to determine the suitability of one product over another.

So, what is the difference?

Simply put, lux is different from lumens because lux takes into account the actual area of which the lumens are spread, while lumens, represent the total quantity of light produced by a light source.

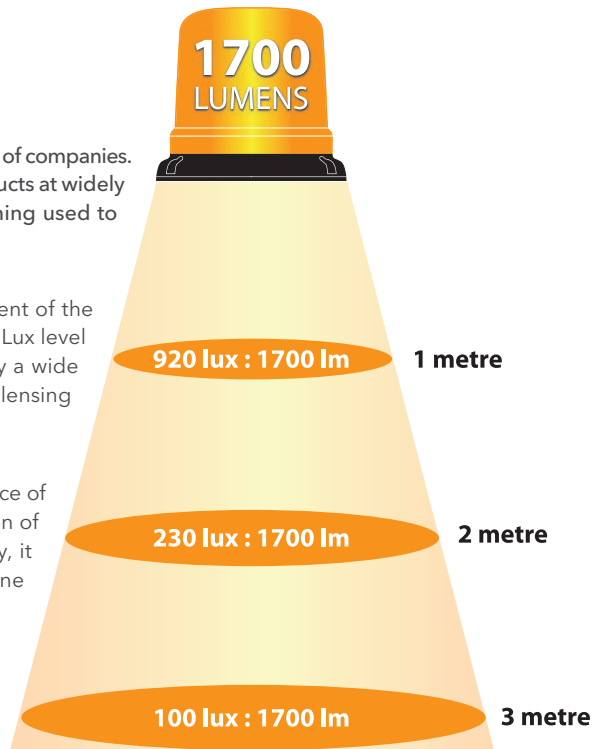

IP Rating

The IP rating system provides a means of classifying the degrees of protection from dust, water and impact afforded by electrical equipment and enclosures. The system is recognised in most European countries and is set out in BS EN 60529:1992.

The classification system utilises the letters 'IP' (Ingress Protection) followed by two or three digits.

Degrees of protection - first digit

The first digit of the IP code indicates the degree that persons are protected against contact with moving parts and the degree that equipment is protected against solid foreign bodies intruding into an enclosure.

Degrees of protection - second digit

The second digit indicates the degree of protection of the equipment inside the enclosure against the harmful entry of various forms of moisture.

FIRST DIGIT		SECOND DIGIT	
PROTECTION FROM SOLID OBJECTS		PROTECTION FROM MOISTURE	
0	NON PROTECTED	0	NON PROTECTED
1	Protected against solid objects greater than 50mm, such as a hand.	1	Protected against dripping water
2	Protected against solid objects greater than 12mm, such as a finger.	2	Protected against dripping water when tilted up to 15°
3	Protected against solid objects greater than 2.5mm, such as wire or a tool.	3	Protected against spraying water at an angle of up to 60°
4	Protected against solid objects greater than 1.0mm, such as wire or thin strips.	4	Protected against splashing water from any direction
5	Dust protected. Prevents ingress of dust sufficient to cause harm.	5	Protected against jets of water from any direction
6	Dust tight. No ingress of dust.	6	Protected against heavy seas or powerful jets of water
		7	Protected against the effects of temporary immersion
		8	Protected against the effects of continuous immersion
		9k	Protected against the effects of high pressure cleaning/steam jet

For example:

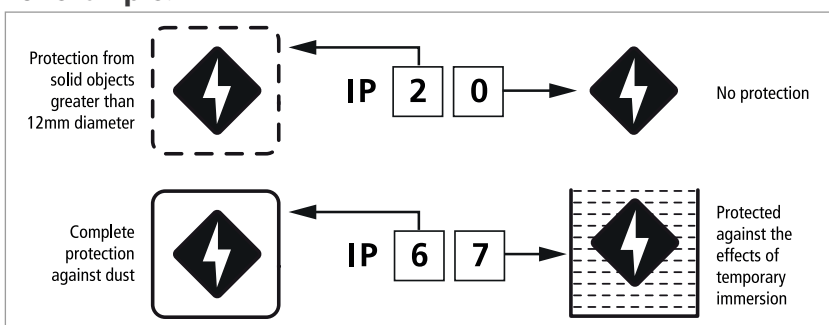

Concurrent Lighting Regulations Guide

Chapter 8 Requirements

Vehicle Warning Lighting:

'Chapter 8' in the UK Government Traffic Signs Manual are a series of traffic safety measures for vehicles situated at road works and temporary situations. They include recommendations for vehicle warning lights, including beacons, when a vehicle is stopped on the highway for works purposes or inspections, as well as entering, leaving or moving within a works site and when travelling in traffic at less than general traffic speed.

The manual 'suggests' that vehicles in road side works or inspections should be equipped with either a roof mounted amber lightbar, comprising of at least **'two independent light sources'** or **'two independent roof mounted amber beacons'**, visible through 360 degrees. In some European countries, which is the case in the UK, all amber warning products used must comply with the requirements of Road Vehicle Lighting Regulations and be ECE Regulation 65 approved to ensure the correct intensity of light output is omitted.

Reflective Livery:

- All vehicles over 7½ tons that need to stop on the highway, ie Highway Maintenance vehicles.
- They must have red prismatic reflective and yellow fluorescent 'dayglow' chevron at the rear of the vehicle.
- They must also have a reflective amber side stripe ECE104 along each side of the vehicle.

Although not mandatory, many operators have extended this to all their vehicles where practical below the 7½ ton threshold. Additional information can be found at REMA (Retroreflective Equipment Manufacturers Association).

For more information on Chapter 8 requirements visit: www.gov.uk/governmentpublications/traffic-signs-manual.

Regulation UN ECE R65 Requirements

Regulation 65:

This regulation known as 'United Nations Commission for Europe (UNECE) Regulation 65 on Special Warning Lamps' covers labelling, light output (intensity and dispersion), flash rate and colour for beacons, lightbars and directional lights, where the key points are briefly:

- Regulation 65 applies to rotating and directional warning lights, such as those utilised in lightbars and additional vehicle lighting
- It sets a standard for colour, light intensity, light distribution and frequency. Heat resistance, cold start and water ingress are also measured
- Manufacturers must ensure that all products carrying this approval consistently comply with the standards
- Customers can have the confidence that products showing this approval, meet the necessary standard in all markets which have adopted ECE Regulation 65
- Regulation 65 is now law in all European Countries and is slowly being adopted in most of them. Although now recognised and accepted in the UK at the moment it is currently non-mandatory but is recommended under Chapter 8 section of the Traffic Signs manual (see associated extract on in this section) therefore the take up is slow simply because users are not aware of this requirement. As such, education is needed to ensure this regulation is specified as standard on individual, small and large fleets and particularly government vehicles.
- Although in the UK R65 is currently non-mandatory it is in fact a Regulatory requirement with the UK Emergency Services (Police Fire & Ambulance) to ensure the 'principle' Warning Lights are of sufficient brightness to be seen and make the vehicle presence be known. Also, if a light head is deemed to be of a secondary nature to add extra presence and add to the aesthetic appeal of the vehicle these do not have to be R65 approved. However, to keep matters simple and to avoid any ambiguity it is Standby RSG's preference policy to only offer R65 approved rooftop lighting products to the emergency services. It is also up to the end user or installation company to specify if the device is required to be Class 1 or 2 approved.

Light Output:

Each lightbar, beacon or directional light is tested for light intensity and light dispersion to comply with set conditions for Class I or Class II (night and day intensity levels) for its colour range and product category.

Class I has to achieve the set night light intensity level. Noting this also represents the minimum acceptable level for daytime use and therefore must not fall below this level to comply with Regulation 65.

Class II is able to switch between the set day and night light intensity levels. Therefore, Class II devices by default, can also be classified as being Class I certified, and where in practice the daytime light levels would normally be significantly higher than the minimum acceptable level for Class I certification. Thus, meaning when a device is switched between day and night-time use a visual difference will be noticeable by the naked eye.

For example: A rotating amber beacon would have to meet a set light intensity and 0° and reach a set percentage of light intensity at +/- 8°, through 360° for Class I. To achieve Class II certification the beacon would have to be able to switch to daytime levels, which are 2.3 times brighter for amber. This operational switch is manually operated and not automatic.

Individual products are identified as a series of Letters and a Number where:

T = Rotating or stationary 360 degree flashing lamp such as beacons and lightbars

X = Directional flashing light

HT = Covers 270 degrees and typically refers to corner lighting

Number 1 = Class 1 must achieve the set night light intensity level.

Number 2 = Class 2 can switch between set day and night light intensity levels.

A = Amber, **B** = Blue and **R** = Red

Examples:

T1A = Class 1 rotating 360 beacon or lightbar in amber

X2B = Class 2 directional flashing light in blue

Flash Rate:

Flash rate between 2 - 4Hz. Lightbars containing more than 2 light sources in each half of the lightbar must be synchronised with each other.

Labelling:

Each beacon or lightbar type is submitted for test and certification with detailed drawings of the location of all light sources, general assembly of the product and brand name and model. Any changes to these specifications may mean the unit would require re-testing. All ECE R65 labelling must be clearly visible, together with the brand name and model number.

Electromagnetic Compatibility (ECE R10 EMC)

Electromagnetic Compatibility (EMC) is a major quality feature for optical and acoustic signalling systems and describes two factors:

- Radiated interference: the limitation of radiated electromagnetic interference to a level that guarantees the interference-free operation of other devices in the environment
- Immunity to interference: guaranteeing sufficiently high resistance to electro-magnetic interference acting from the outside

SAE Classifications (USA)

SAE is the Society of Automotive Engineers. SAE is comprised of a number of working groups of automotive and lighting engineers that work with industry studies and other experts to set standards. SAE sets the standards for all lighting on a vehicle. While SAE is not law in most areas, it is a best-practices standard that the entire automotive world pays attention to.

SAE classifications are standardised methods of ensuring that the proper lamp is being used for an appropriate function and application.

Civil Aviation Publication 168 (CAP168)

CAP 168 sets out the standards required at UK National licensed aerodromes relating management systems, operational procedures, physical characteristics, assessment and treatment of obstacles, visual aids, rescue and fire fighting services and medical services.

The correct type of beacon or lightbar must not dazzle flight crew in their elevated position to the ground servicing vehicles. The beacon or lightbar light must be static flash Airport CAP168 Compliant.

GDPR - Regulation (EU) 2016/679

RSG hereby confirms it is fully compliant with this Regulation where it stands for 'General Data Protection Regulation'. GDPR, also known as Regulation (EU) 2016/679, is a European Union law drafted April 27, 2016 and instituted May 25, 2018. It replaces the EU Data Protection Directive, which was adopted in 1995. The primary purpose of GDPR is to protect the personal data of residents of countries with the European Union (EU).

Warranty Guidelines

Unless otherwise stated RSG's standard warranty period is a one year return to base service, for full terms and conditions please contact our sales department or view on our website.