

LED FLUSH MOUNT KIT USER MANUAL

12-24VDC

CONTENTS



LIGHTHEAD x 2pcs



MOUNTING GROMMET x 2pcs



EXTENSION CABLE



LED CONTROLLER

WIRING & FUNCTIONS

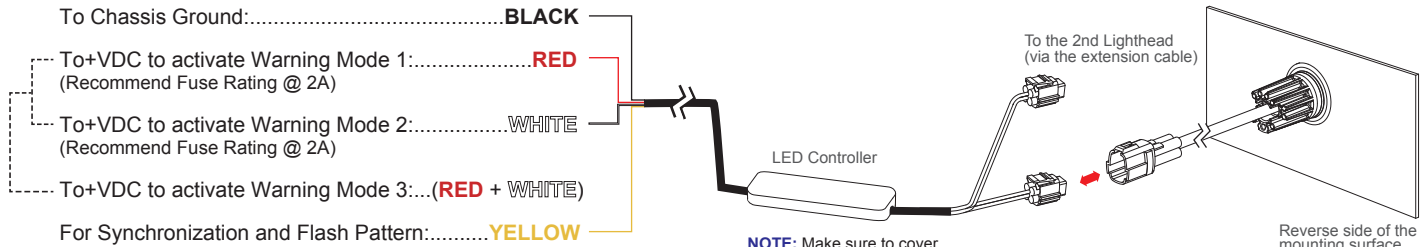

NOTE: Each warning mode may be set to different Flash Pattern & Colour Mode.

OPERATION

For Synchronization:

Connect **YELLOW** wires of all lighthoods together for synchronization.
(All the lighthoods should be set to the same Flash Pattern)

For Warning Colour Mode:

Each Warning Mode (**RED**, **WHITE** or **RED+WHITE**) may be set to warning in **COLOUR 1**, **COLOUR 2** or **COLOUR 1 2**. To change Warning Colour Mode:

- Choose the desired warning mode to change and apply +VDC to its activation wire (**RED**, **WHITE** or **RED+WHITE**) with **YELLOW** wire simultaneously to enter *Setting Mode*; lighthouse will display short flashes in its current Colour Mode.
 - Colour 1 (Warning Mode 1 Pre-set)
 - Colour 2 (Warning Mode 2 Pre-set)
 - Colour 1 alt. 2 (Warning Mode 3 Pre-set)
- Remove **YELLOW** wire from +VDC and momentarily apply to +VDC again to change Colour Mode.
- Once in desired Colour Mode, save and Exit *Setting Mode* by powering off the lighthouse.

For Flash Pattern:

While a warning mode is activated, momentarily apply +VDC to **YELLOW** wire:

- once for next pattern
- quick three times to reset to FP#1 (see flash pattern chart)

Flash Pattern

1	Double [2Hz]	14	Random
2	Single [2Hz]	15	Double [2Hz] (SPLIT)
3	Triple [2Hz]	16	Single [2Hz] (SPLIT)
4	Quad [2Hz]	17	Triple [2Hz] (SPLIT)
5	Single	18	Quad [2Hz] (SPLIT)
6	Double	19	Single (SPLIT)
7	Quad	20	Double (SPLIT)
8	Quint	21	Quad (SPLIT)
9	Mega	22	Quint (SPLIT)
10	Ultra	23	Mega (SPLIT)
11	Single-Quad	24	Ultra (SPLIT)
12	Single H/L	25	Single-Quad (SPLIT)
13	Steady	26	Single H/L (SPLIT)

INSTALLATION - FLUSH MOUNT

- Select a mounting location and drill one 1" (25.4mm) cut-out.

NOTE: Mounting surface thickness @ 0.8~2.0mm

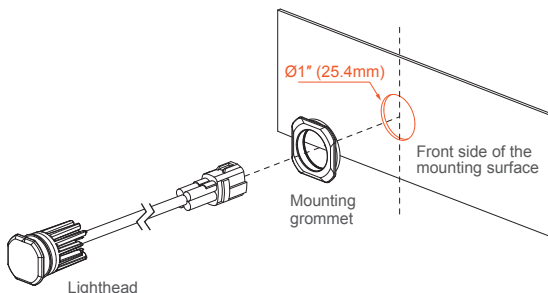

- Ensure that triangle mark on the lens is aligned vertically.

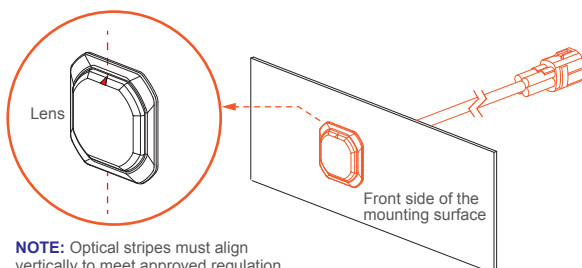

- From the front, install MOUNTING GROMMET onto the cut-out, and then insert the LIGHTHEAD.

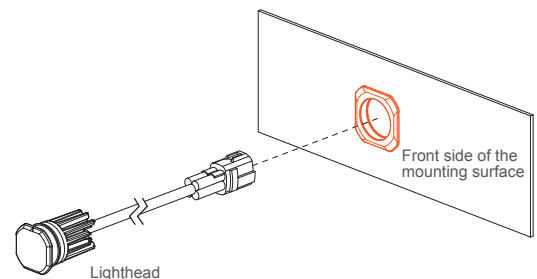

- Where necessary, apply silicone around the reverse side to prevent from rotating.

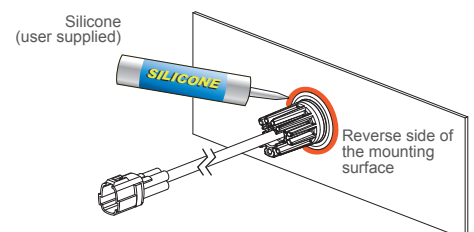

INSTALLATION - BRACKET MOUNT (sold-separately)

1 From the front, install the MOUNTING GROMMET onto the BRACKET, and insert the LIGHTHEAD.

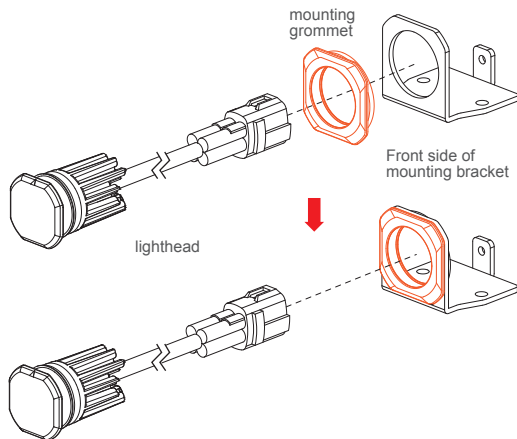

2 Ensure that triangle mark on the lens is aligned vertically.

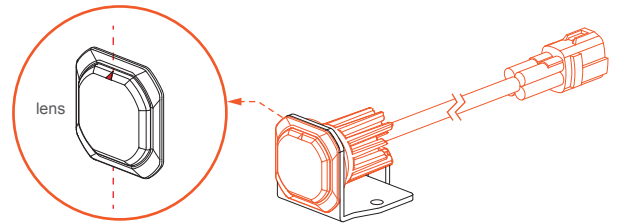

NOTE: Optical stripes must align vertically to meet approved regulation.

3 Secure the LIGHTHEAD onto the BRACKET with a screw.

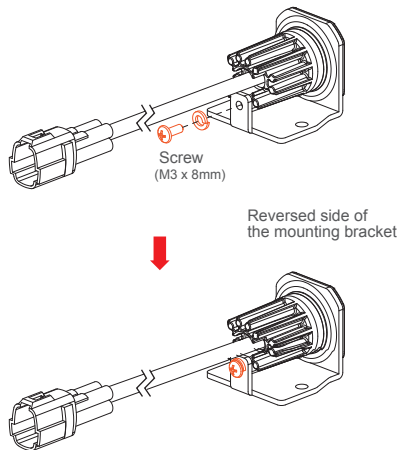

4 Secure the BRACKET onto the desired mounting surface with screws.

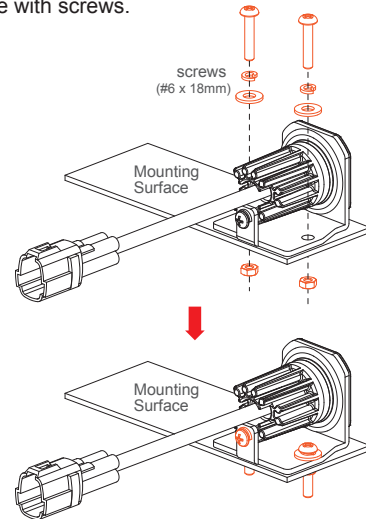

WIRING 2 KITS TOGETHER

Below is a schematic diagram for wiring 2 kits together.

Yellow wires from both controllers must be connected together for synchronization.

- When Flash Pattern 1~12 is selected: All Heads will flash simultaneously.
- When Flash Pattern 15~26 is selected: Head 1A&2A will flash alternatively with Head 1B&2B.

*refer to Flash Pattern chart on opposite page.

NOTE: To have Head 1A&2B alternate with 1B&2A, simply reverse the lighthouse outlets on one of the Controllers; (both kits must be in Flash Pattern 15~26).

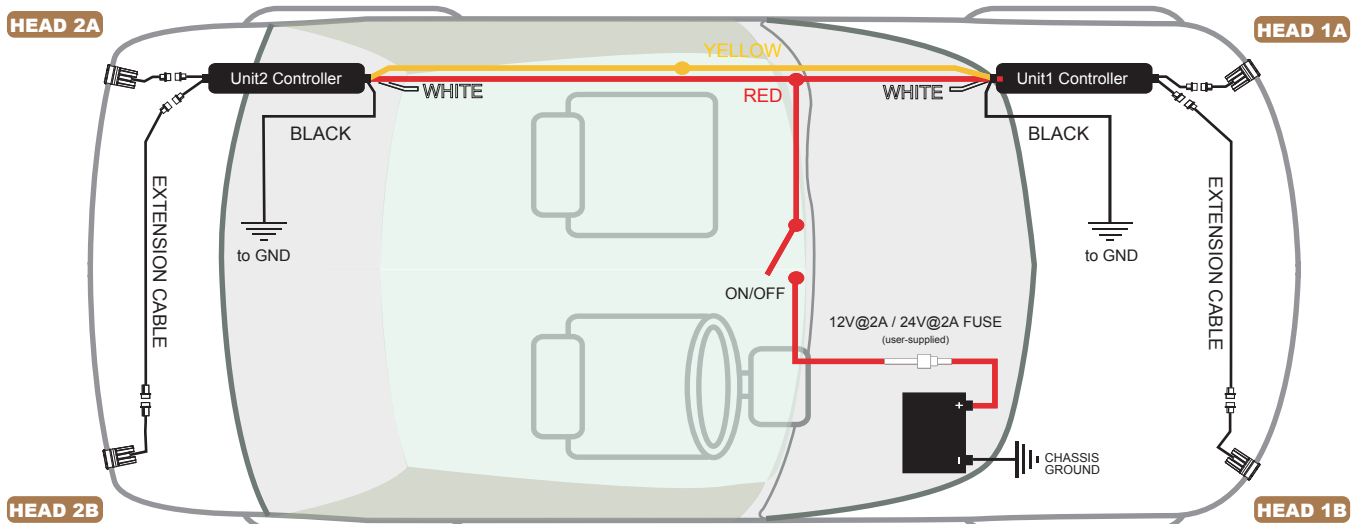

NOTE: The mounting area for controllers varies from vehicle to vehicle.